



Nothing but **HEAVY DUTY**

**MILWAUKEE TOOL**

Milwaukee Electric Tool Corporation  
 BROOKFIELD, WI 53005  
 USA  
 Tel: +1 (262) 781-3600 • Fax: +1 (262) 790-6333

Milwaukee Asia Office  
 29/F, Tower 2, Kowloon Commerce Centre,  
 51 Kwai Cheong Road, Kwai Chung, Hong Kong  
 Tel: +852-2492-2181 • Fax: +852-2490-4778

Distributed by:

12/1/2022

All data incl. service and warranty conditions as well as product range are subject to change without notice. Pictures not binding. No liability for printing errors or mistakes. © 2022 Milwaukee Electric Tool Corporation. All trademarks are owned by Techtronic Cordless GP unless otherwise stated.

[www.milwaukeetool.asia](http://www.milwaukeetool.asia)

**Milwaukee™**

**M18 FUEL™**  
 DRIVEN TO OUTPERFORM.™

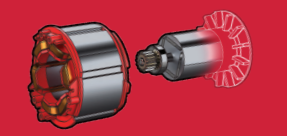

**POWERSTATE™  
 BRUSHLESS MOTOR**

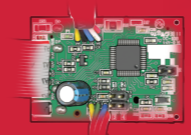

**REDLINK PLUS™  
 INTELLIGENCE**



**REDLITHIUM  
 BATTERY PACK**

M18 FHP /  
 M18 FHPX  
**M18 FUEL  
 32MM  
 HAMMER**

**FASTER  
 DRILLING**

**AUTOSTOP  
 CONTROL  
 ENHANCED  
 SAFETY**

UP TO  
**30** 18MM x 100MM  
**HOLES**  
 PER CHARGE



## DRIVEN TO OUTPERFORM.

M18 FUEL is engineered for the most demanding tradesmen in the world. Delivering unrivaled performance in a compact structure, all M18 FUEL products feature three MILWAUKEE exclusive innovations - the POWERSTATE Brushless Motor, REDLITHIUM Battery Pack and REDLINK PLUS Intelligence Hardware and Software - that deliver unmatched power, run-time and durability.

## M18 FUEL™

### 3 MODES OF OPERATION

Rotary hammer, hammer only, and rotary only modes to meet any users' need

### SDS PLUS & FIXTEC CHUCK

Works with any SDS Plus accessories



### LED LIGHT

Illuminates drilling surface

### CONNECTION PORT DEDICATED DUST EXTRACTOR

Connects easily to dedicated dust extractor (M18 FPDDEXL)

### EXTENDED CAPACITY

Extended design allows users to drill up to 203mm in depth, 32mm in diameter

### SMALL + LARGE DUST NOZZLES

Small and Large Diameter Dust Nozzles allow users to drill up to 32mm in diameter

### TRANSLUCENT DUST BOX W/ VACUUM PORT

Allows user to see when the dust box is full. Vacuum port allows user to attach to large dust extractor to suction out dust from box for limited exposure to debris



### HEPA FILTER

Includes Certified HEPA Filter



### AUTOSTOP KICKBACK CONTROL

Electronically shuts down the tool to protect the user after 45° of sharp movement in bind up situations

### AVS ANTI-VIBRATION SYSTEMS

Reduces vibration to deliver the most comfortable user experience

### REDLINK PLUS INTELLIGENCE

Advanced electronic communication optimizes tool performance

### POWERSTATE BRUSHLESS MOTOR

Delivers the fastest drilling speeds

### ADJUSTABLE DEPTH GAUGE

Easily adjusts for accurate hole depths

### POWERED BY ROTARY HAMMER

Connects to M18 FHP/FHPX rotary hammers and is powered by the same battery as the tool

### AUTOPULSE FILTER CLEANING MECHANISM

Industry's first automatic filter cleaning mechanism for an on-tool extractor

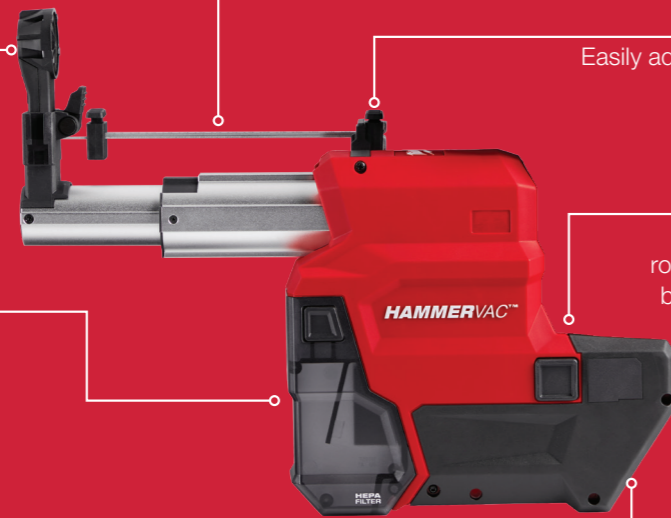

## 32MM SDS PLUS ROTARY HAMMER

### FASTER DRILLING

#### INCREASED PRODUCTIVITY

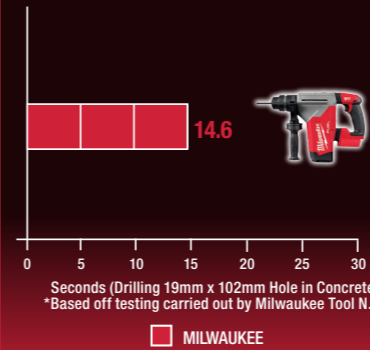

- POWERSTATE Brushless Motor delivers 5.0J impact energy for faster drilling speeds
- Less time spent drilling to stay productive

### AUTOSTOP CONTROL ENHANCED SAFETY

#### MAXIMUM CONTROL



Senses kickback and stops rotation

- AUTOSTOP Kickback Control Shuts the tool off in a bind up situation, preventing over rotation

### UP TO 30 18MM X 100MM HOLES PER CHARGE

#### LESS DOWNTIME



M18™ HIGH OUTPUT 8.0Ah

Diameter	Depth	# of Holes
18mm	100 mm	30

- Delivers a full day of run-time for most users with the M18 REDLITHIUM HIGH OUTPUT 8.0Ah Battery Pack



## SPECIFICATIONS

DESCRIPTION	SPECIFICATIONS	DESCRIPTION	SPECIFICATIONS
Max Capacity	32mm	Kickback Prevention	Yes
Impact Energy	5.0 J	Anti-Vibration	Yes
BPM	4,600	Dedicated Dust Management	Yes
RPM	800	Weight	3.8 kg (FIXTEC: 4.0 kg)