

Milwaukee™

Nothing but **HEAVY DUTY™**



M18 FRT

- ⓔⓃ User Manual
- Ⓩⓗ 操作指南
- Ⓩⓗ 操作指南
- Ⓚⓐ 사용시 주의사항
- Ⓣⓗ คู่มือการใช้งาน
- ⓓⓔ Buku Petunjuk Pengguna
- Ⓥⓞ Cẩm nang hướng dẫn sử dụng
- ⓙⓐ ユーザーマニュアル

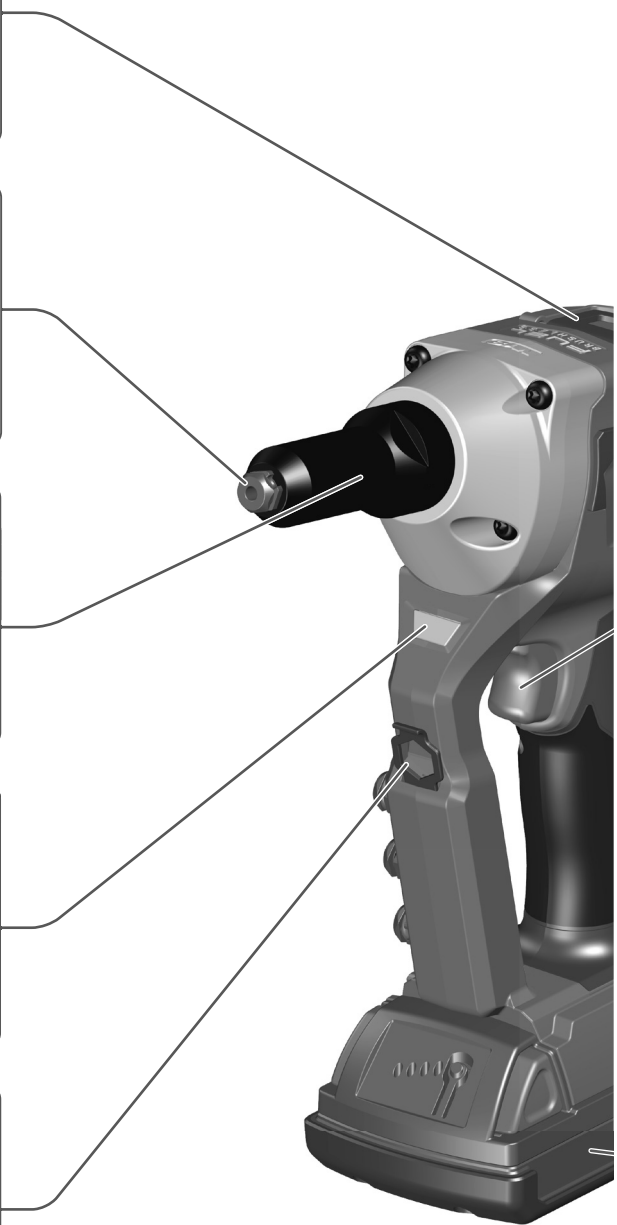
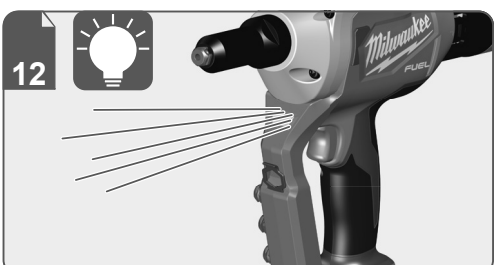
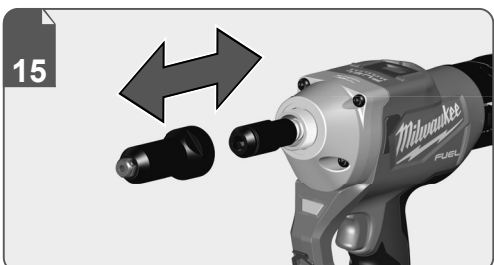

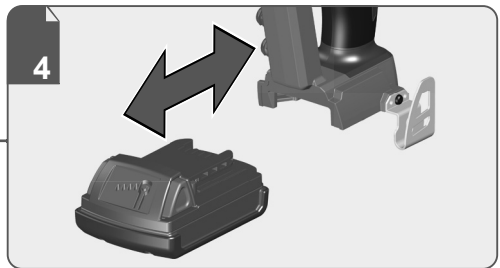
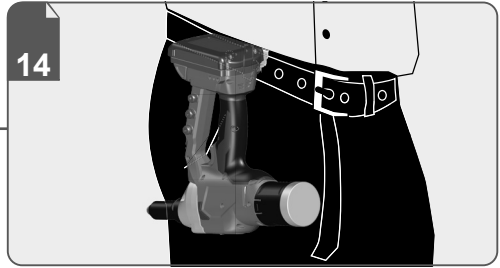
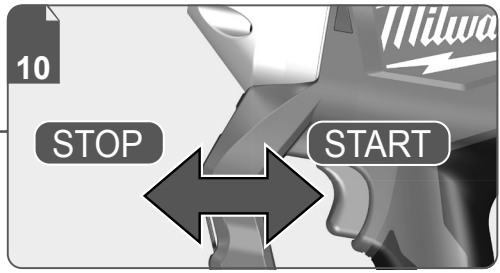
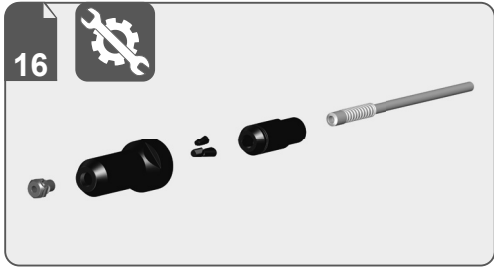

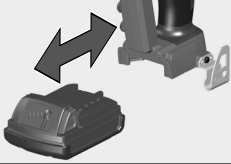

Remove the battery pack before starting any work on the product.

在產品上開始任何工作之前，請先取出電池組。

在产品上开始任何工作之前，请先取出电池组。

제품 사용 전, 배터리 팩을 제거하십시오.

ถอดชุดแบตเตอรี่ออกก่อนเริ่มการทำงานใด ๆ กับผลิตภัณฑ์

Lepaskan paket baterai sebelum memulai pekerjaan apa pun pada produk.

Tháo pin trước khi bắt đầu thao tác với sản phẩm.

製品のメンテナンス、アクセサリを交換する前に、バッテリーパックを取り外してください。

1

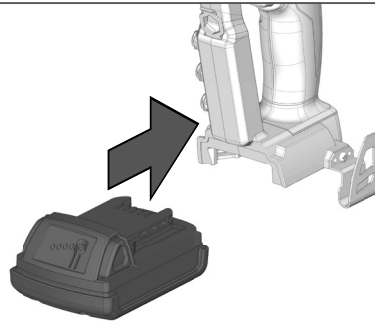

2

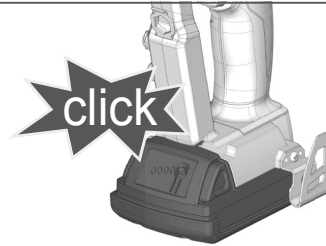

1

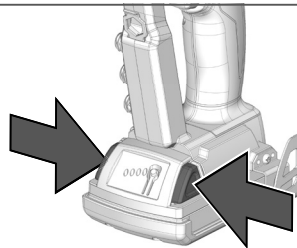

2

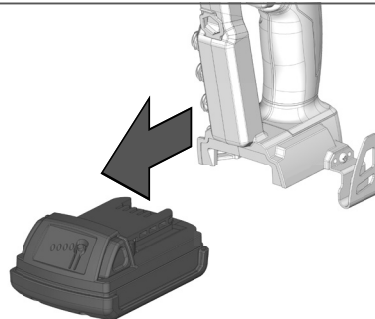

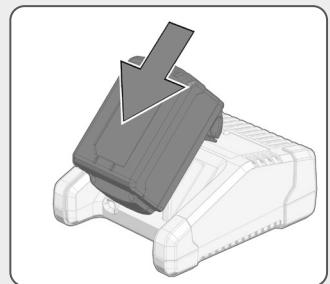
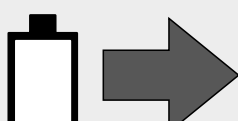
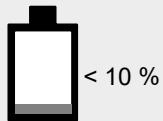
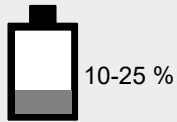
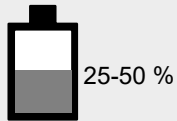
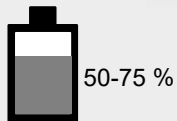
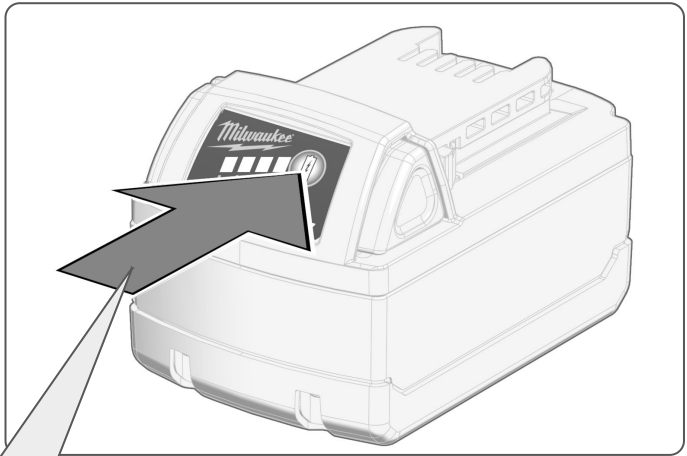

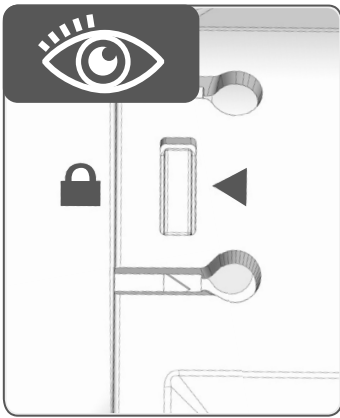
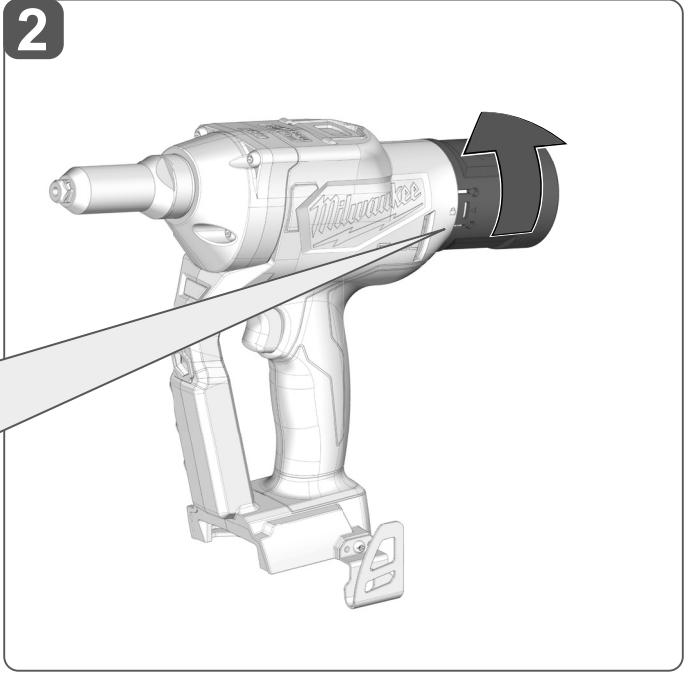
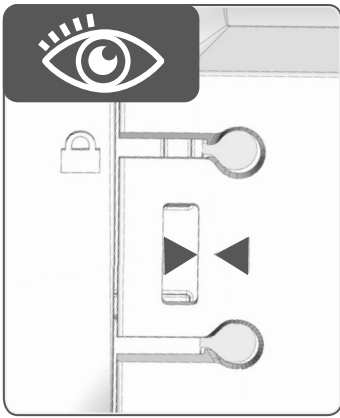
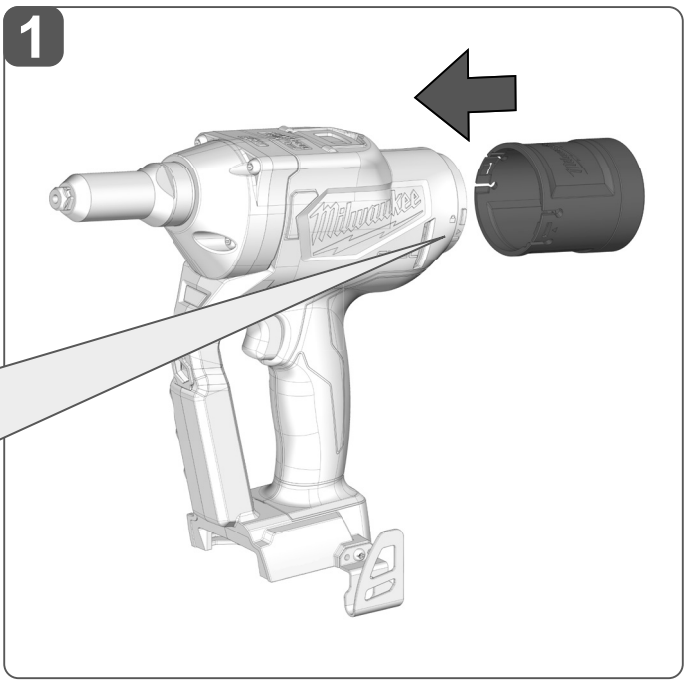



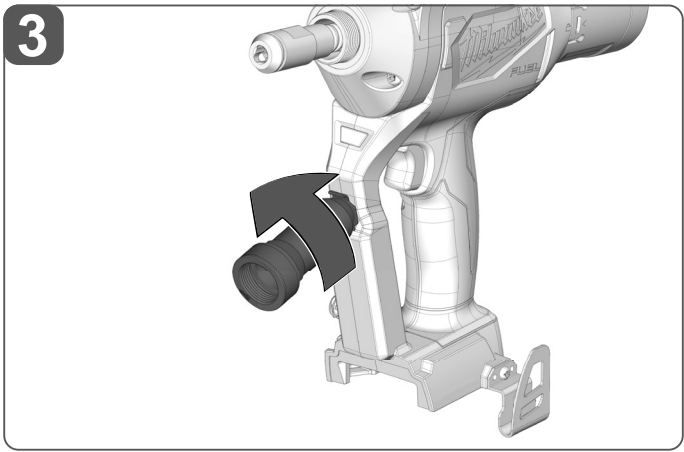
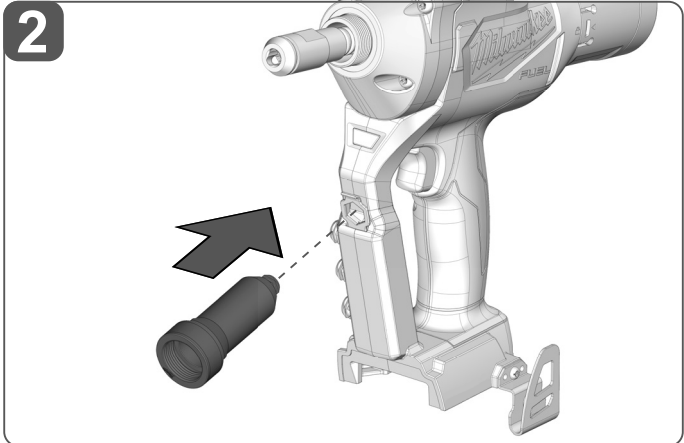
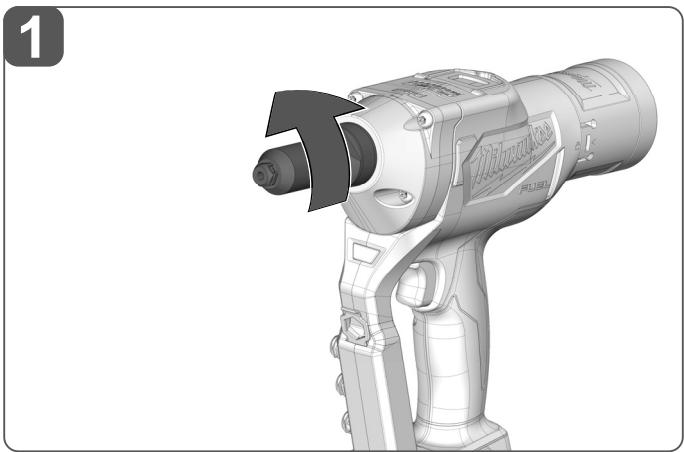

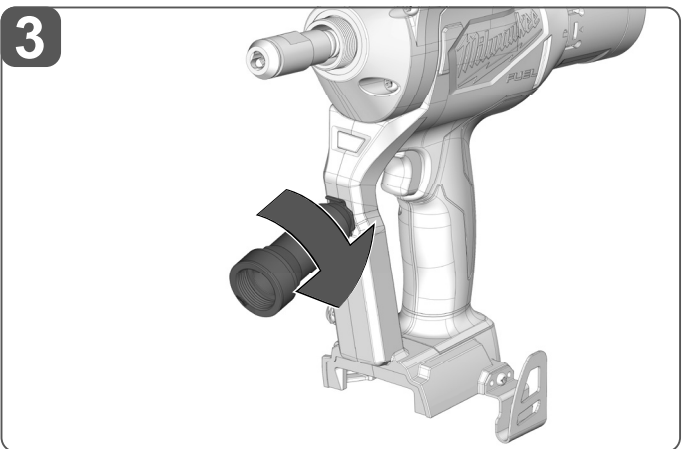
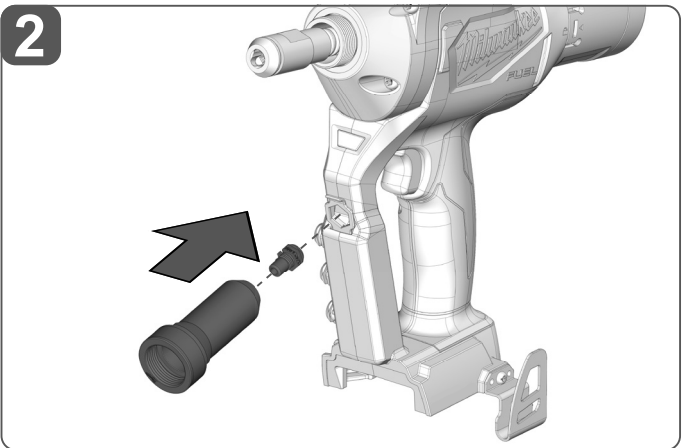
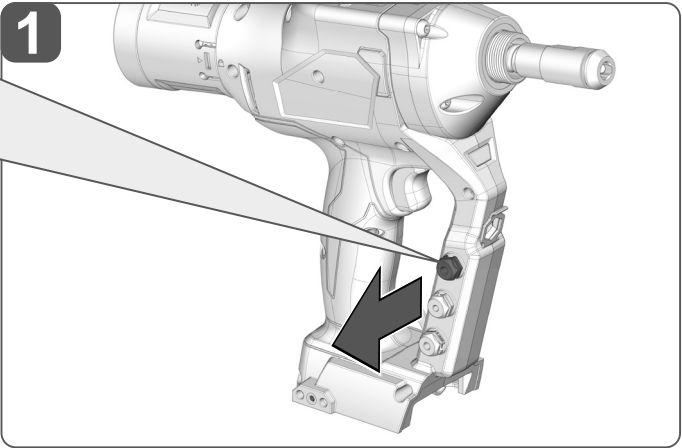
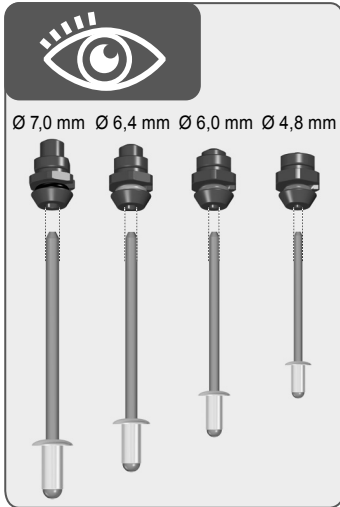

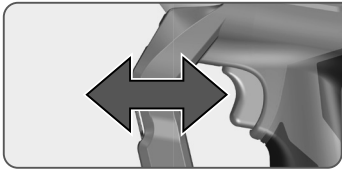

1

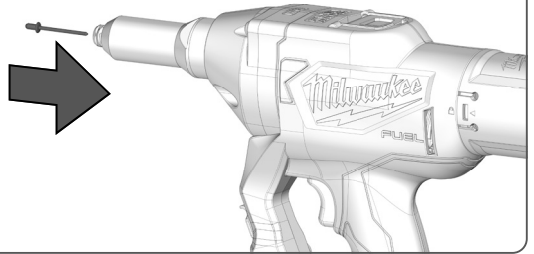

2

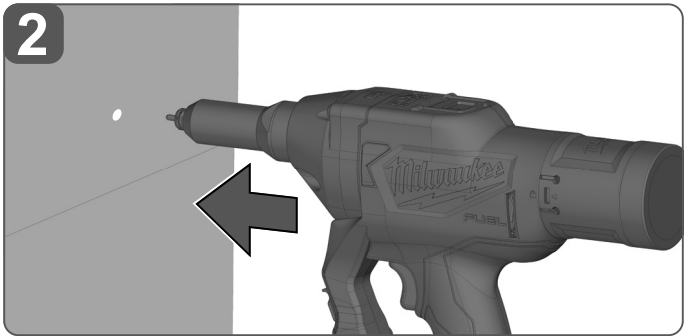

START



AUTO-STOP

START

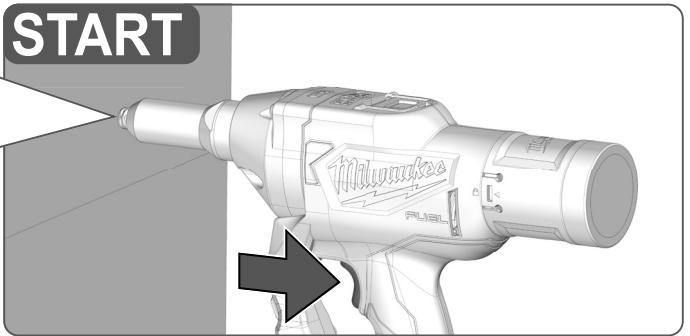

STOP

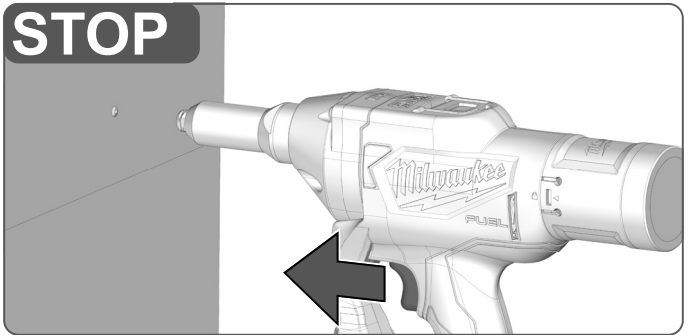



Insulated gripping surface

絶縁の把手

绝缘的把手

절연 그립 표면

พื้นผิวจับกันความร้อน

Permukaan genggam berinsulasi

Bề mặt tay cầm được cách điện

絶縁グリップ面

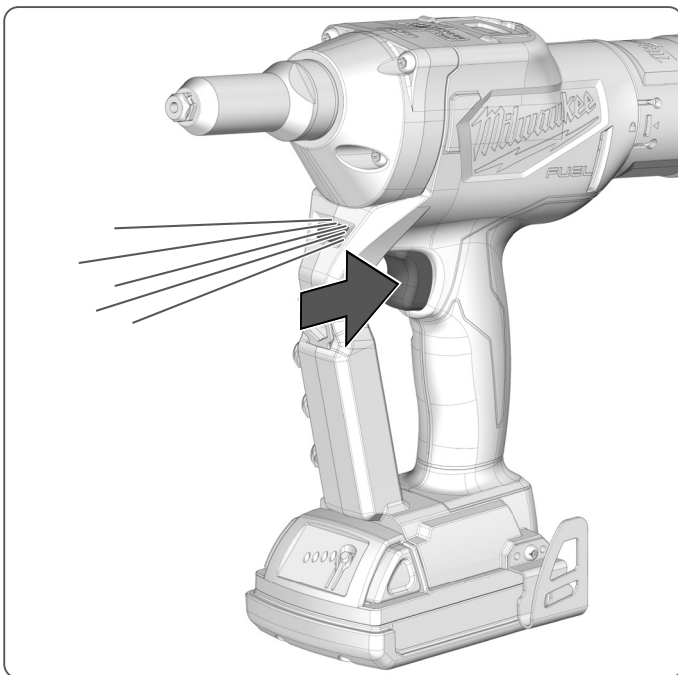



1

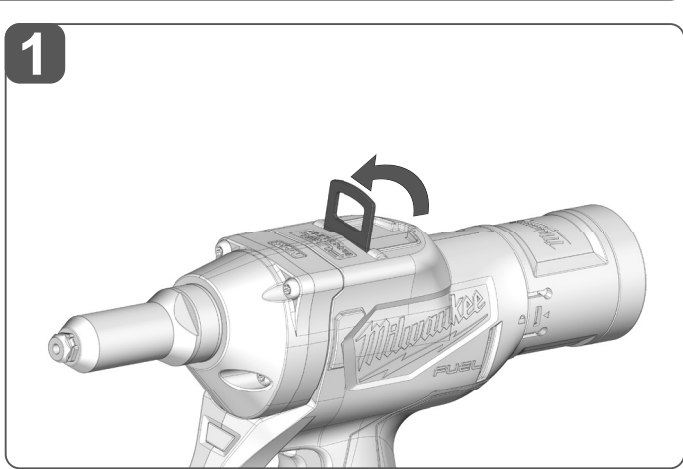

2



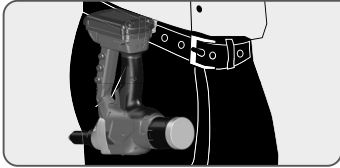

1

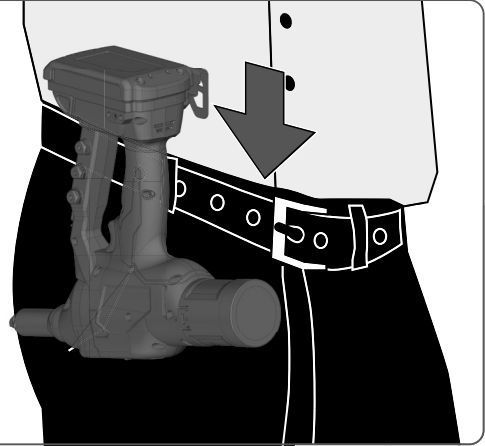

2

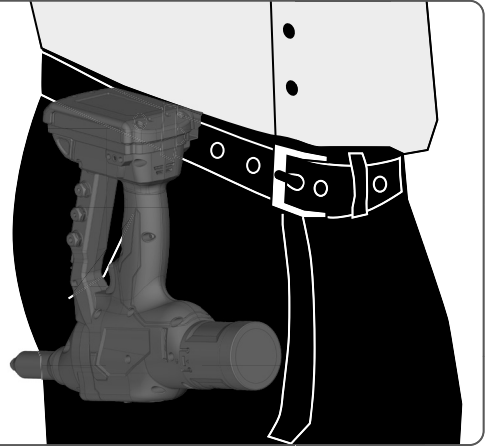

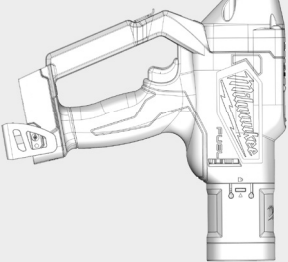
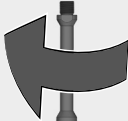
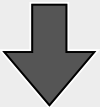
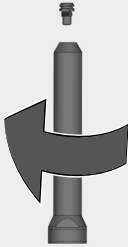



1 5000 x

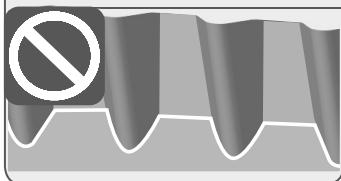
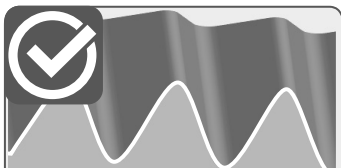
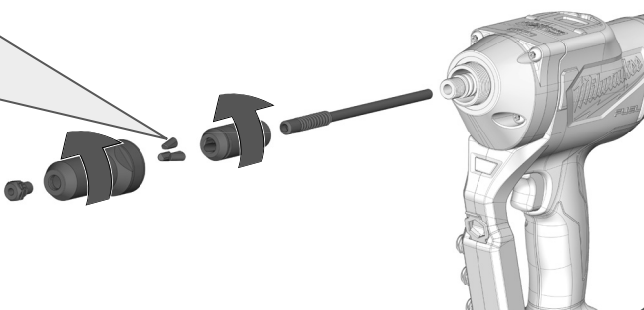

2



3

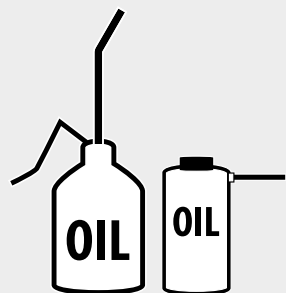

TECHNICAL DATA	M18 FRT
Battery voltage	18 V
Pull force	20000 N
Tool stroke length	30.0 mm
Jaw diameter max	7.0 mm
Rivet size Ø	
Black	4.8mm
Red	6.0mm
Green	6.4mm
Brown	7.0mm
Rivet material	Aluminium
	Copper
	Steel
	Stainless steel
Weight according EPTA-Procedure 01/2014 (Li-Ion 2.0 Ah - 12.0 Ah)	2.5 - 3.5 kg
Recommended ambient operating temperature	0 - +50 °C
Recommended battery types	M18B...; M18HB...
Recommended charger	M12-18...; M1418C6
Noise emission values determined according to EN 62841.	
A-weighted sound pressure level	81 dB (A)
Uncertainty K	3dB (A)
A-weighted sound power level	92 dB (A)
Uncertainty K	3dB (A)
Wear ear protectors.	
Vibration total values (triaxial vector sum) determined according to EN 62841	
Vibration emission value	$a_n = < 2.5 \text{ m/s}^2$
Uncertainty K	1.5 m/s ²

WARNING!

The declared vibration total values and the declared noise emission values given in this instruction manual have been measured in accordance with a standardised test and may be used to compare one tool with another. They may be used for a preliminary assessment of exposure.

The declared vibration and noise emission values represent the main applications of the tool. However, if the tool is used for different applications, used with different accessories, or poorly maintained, the vibration and noise emission may differ. These conditions may significantly increase the exposure levels over the total working period.

An estimation of the level of exposure to vibration and noise should take into account the times when the tool is turned off or when it is running idle. These conditions may significantly reduce the exposure level over the total working period.

Identify additional safety measures to protect the operator from the effects of vibration and noise, such as maintaining the tool and the accessories, keeping the hands warm (in case of vibration), and organising work patterns.

⚠ WARNING! Read all safety warnings, instructions illustrations and specifications provided with this power tool. Failure to follow all instructions listed below may result in electric shock, fire and/or serious injury.

Save all warnings and instructions for future reference.

RIVET TOOL SAFETY WARNINGS

Hold the power tool by the insulated gripping surfaces only when performing an operation where the fastener may contact hidden wiring. Contact with a “live wire makes the exposed metal parts of the power tool “live” and could give the operator an electric shock.

Use protective equipment. The use of protective clothing is recommended, such as dust mask, protective gloves, sturdy non-slip footwear, helmet, and ear defenders.

Have the damage parts repaired immediately in an authorised service centre.

Remove the battery pack before starting any work on the product.

To avoid injury and damage, never immerse the product, battery pack or charger in liquid or allow liquid to penetrate them.

ADDITIONAL SAFETY AND WORKING INSTRUCTIONS

⚠ WARNING! To reduce the risk of fire, personal injury, and product damage due to a short circuit, never immerse the product, battery pack, or charger in fluid or allow fluid to flow inside them. Corrosive or conductive fluids, such as seawater, certain industrial chemicals, and bleach or bleach-containing products, etc., can cause a short circuit.

Never break open battery packs and chargers and store them only in dry rooms. Keep the battery packs and chargers dry at all times.

Use only M18 System chargers for charging M18 System battery packs. Do not use battery packs from other systems.

WARNING! The product contains a button-type/coin cell lithium battery. A new or used battery can cause severe internal burns and lead to death in as little as 2 hours if swallowed or if it enters the body. Always secure the cover on the battery compartment. If it does not close securely, stop the device, remove the battery and keep it out of reach of children. If you believe that someone has swallowed the battery or that it has otherwise entered the body, seek immediate medical attention.

SPECIFIED CONDITIONS OF USE

This blind riveting power tool is designed for professional blind rivet setting applications.

Do not use the product for any other purpose.

RESIDUAL RISKS

Even when the product is used as prescribed, it is still impossible to completely eliminate certain residual risk

factors. The following hazards may arise during use and the operator should pay special attention to avoid the following:

- injury caused by vibration
 - Hold the product by designated handles and restrict working time and exposure.
- exposure to noise can cause hearing injury
 - Wear ear protection and limit exposure.
- injury due to flying debris
 - Wear eye protection, heavy long trousers, gloves and substantial footwear at all times.
- health hazards caused by breathing toxic dusts
 - Wear a mask if necessary.

BATTERIES

Battery packs that have not been used for some time should be recharged before use.

Temperatures in excess of 50°C reduce the performance of the battery pack. Avoid extended exposure to heat or sunshine (risk of overheating).

The contacts of chargers and battery packs must be kept clean.

For an optimum lifetime, the battery packs have to be fully charged, after use.

To obtain the longest possible battery life, remove the battery pack from the charger once it is fully charged.

For battery pack storage longer than 30 days:

- Store the battery pack where the temperature is below 27°C and away from moisture.
- Store the battery packs in a 30% - 50% charged condition.
- Every six months of storage, charge the battery pack as normal.

BATTERY PACK PROTECTION

In extremely high torque, binding, stalling and short circuit situations that cause high current draw, the product vibrates for about 5 seconds, the fuel gauge flashes, and then the product turns off.

To reset, release the trigger. Under extreme circumstances, the internal temperature of the battery pack could raise too much. If this happens, the fuel gauge flashes until the battery pack cooled down. After the lights go off, the work may continue.

TRANSPORTING LITHIUM BATTERIES

Lithium-ion batteries are subject to the Dangerous Goods Legislation requirements. Transportation of those batteries has to be done in accordance with local, national and international provisions and regulations.

- Batteries can be transported by road without further requirements.
- Commercial transport of Lithium-ion batteries by third parties is subject to Dangerous Goods Regulations. Transport preparation and transport are exclusively to be carried out by appropriately trained persons and the process has to be

accompanied by corresponding experts.

When transporting batteries:

- Ensure that battery contact terminals are protected and insulated to prevent short circuit.
- Ensure that battery pack is secured against movement within packaging.
- Do not transport batteries that are cracked or leaking.

Check with the forwarding company for further advice.

CLEANING

The ventilation slots of the product must be kept clear at all times.

MAINTENANCE

Use only MILWAUKEE accessories and MILWAUKEE spare parts.

Should components that have not been described need to be replaced, contact one of our MILWAUKEE service centres (see our list of guarantee or service addresses).

If needed, an exploded view of the product can be ordered. State the product type and the serial number on the label, and order the drawing at your local service centres.

SYMBOLS



Read the instructions carefully before starting the product.



CAUTION! WARNING! DANGER!



Remove the battery pack before starting any work on the product.



Always wear goggles when using the product.



Wear gloves!



Accessory - Not included in standard product; available as an accessory.



Do not dispose of electric tools, batteries, or rechargeable batteries together with household waste material. Electric tools and batteries that have reached the end of their life must be collected separately and returned to an environmentally compatible recycling facility. Check with your local authority or retailer for recycling advice and collection point.

V

Voltage



Direct current

技術數據	M18 FRT
電池電壓	18 V
拉力	20000 N
刀具的行程長度	30.0 mm
夾爪的最大直徑	7.0 mm
鉚釘的尺寸 Ø	
黑色	4.8mm
紅色	6.0mm
綠色	6.4mm
棕色	7.0mm
鉚釘的材料	鋁 銅 鋼 不鏽鋼
根據EPTA-Procedure 01/2014的重量 (Li-Ion 2.0 Ah - 12.0 Ah)	2.5 - 3.5 kg
建議環境操作溫度	0 - +50 °C
推薦的電池類型	M18B... ; M18HB...
推薦充電器	M12-18... ; M1418C6
依 EN 62841 所測的測量值。	
A加權聲壓值	81 dB (A)
不確定性的測量 K	3dB (A)
A加權聲功率級	92 dB (A)
不確定性的測量 K	3dB (A)
佩戴護耳器。	
依EN 62841所測的震動總值 (三軸向量總和)。	
震動釋放值	$a_n = < 2.5 \text{ m/s}^2$
不確定性的測量 K	1.5 m/s ²

警告！

本說明書所提供的震動等級是依標準化測試所測得，且可能用於與另一個工具進行比較。該等級可用來初步評估風險。

宣告的震動釋放等級代表的是本工具的主要應用。然而，如果用於不同的應用、使用不同的配件或保養不當，震動釋放也可能不同。這可能會在總工作時間上顯著增加風險等級。

評估震動暴露的等級還應考慮本工具關機時的時間，或當工具運轉但卻未實際使用的時間。這可能會明顯降低總工作期間的風險等級。

請確認額外的安全措施，以保護操作員不受震動的影響，例如：保養本工具與配件、保持手部溫暖和井然有序的工作方式。

▲ 警告！請閱讀本產品隨附的所有安全警告、說明、插圖及規格。若不按照警告和說明操作，則可能會導致觸電、火災和/或嚴重傷害。

將所有警告和說明保存好，方便以後查閱。

鉚釘工具安全警告

在緊固件可能觸及暗線或其自身軟線之處進行操作時，要通過絕緣握持面來握持工具。緊固件碰到帶電導線會使工具外露的金屬零件帶電從而使操作受到電擊。

使用防護裝備。使用機器時，務必佩戴護目鏡。建議穿戴防護裝備，例如防塵罩、防護手套、堅固防滑的鞋具、安全帽和護耳器。

損壞的產品應立刻由授權的中心維修。

對產品進行任何工作前，先移除電池。

為避免受傷和損壞，切勿將產品、可拆卸電池或充電器浸入液體中或使液體滲透。

其他安全和工作說明

▲ 警告！為了減少因短路而導致火災、人身傷害和產品損壞的風險，請勿將工具、電池組或充電器浸沒在流體中或使流體流入其中。腐蝕性或導電性流體（如海水、某些工業化學品、以及漂白劑或含漂白劑的產品等）都會導致短路。

不可拆開電池和充電器。電池和充電器必須儲藏在乾燥的空間，勿讓濕氣滲入。必須經常保持乾燥。

僅可使用M18系統充電器對M18系統電池進行充電。請勿使用其他系統的電池。

警告！本產品包含一個鈕扣型/鈕扣式鋰電池。一個新的或已使用的電池均可能導致嚴重的內部灼傷。如果吞嚥或進入身體，可在短短2小時內導致死亡。務必固定電池艙的盒蓋。如果沒有安全地關閉，請停止設備，取出電池，並將其放在兒童接觸不到的地方。如果您認為有人吞下了電池或者進入身體，請立即就醫。

特定使用條件

本產品的用途為專業的拉釘設定應用。

切勿將本產品用於正常使用之外的其他用途。

殘餘風險

即便已按規定使用產品，仍然不可能完全消除某些殘留的風險因素。以下危害可能在使用過程中出現，操作者應特別注意避免以下幾點：

- 振動引起的損傷
 - 用指定的把手握住產品，並限制工作時間及暴露。
- 因接觸噪聲導致聽力傷害
 - 佩戴耳罩和限制暴露於噪音中。
- 因工作拋出的碎屑導致的傷害
 - 務必佩戴防護眼鏡，重型長褲、手套及結實的鞋類。
- 因吸入粉塵所導致的健康危害
 - 必要時可戴面罩。

電池

久未使用的電池必須重新充電後再使用。

超過50°C (122°F)的高溫會降低電池的效能。避免暴露於高溫或陽光下（可能導致過熱）。

充電器和電池組的接點處應保持清潔。

為確保最佳電池使用壽命，電池組使用後應再完全充電。

為確保電池的最長壽命，充電完成後，勿將電池匣繼續留在充電器上。

電池儲存時間長於30日：

- 將電池組存放於溫度低於27°C的環境，且避免受潮；
- 將電池組保持在充電量30%-50%的狀態；
- 存放中的電池組應每六個月照常充電一次。

電池保護

在極高的扭矩、結合、停滯和引起高電流消耗短路的情況下，工具將振動約5秒，電池燈會閃爍，然後工具將關閉。如要重置，鬆開扳機。

如要重置，鬆開扳機。在極端情況下，電池組內部的溫度可能變高。如果發生這種情況，電池將暫時停止運作。如果發生這種情況，電池燈會閃爍直至電池冷卻下來。燈熄滅後，可以繼續工作。

運輸鋰電池

鋰離子電池須受制於危險品法例的要求。

運送鋰電池必須在符合當地、國家及國際標準及法例的情況下進行。

- 使用者可於陸地上運送電池而毋須受限；
- 第三方負責的商業式鋰電池運送須受制於危險品法例。運送的預備及過程必須由受嚴格訓練的人士進行，亦必須得到專家在場監管。

運送電池時：

- 請確保電池接觸終端受到嚴密保護及經過絕緣，防止短路；
- 請確保電池組妥善包裝，防止碰撞磨擦；
- 切勿運送有裂痕或洩漏中的電池。

與速遞公司緊密聯繫以獲得進一步資訊。

清潔

本產品的通風孔必須時刻保持暢通。

維護

只可使用MILWAUKEE的配件和零件。

如果需要更換的組件在此沒有介紹，請與其中一個MILWAUKEE服務代理機構聯繫（參見我們的維修/服務地址列表）。

如果需要機器的分解圖，可以向您的顧客服務中心查詢。請您向當地的顧客服務中心提供以下資料：機器銘牌上產品的號碼及機型。

符號



啟動機器前，請仔細閱讀本說明書。



注意！警告！危險！



對產品進行任何工作前，先移除電池。



使用本產品時務必佩戴護目鏡。



佩戴手套。



配件 - 不包在標配設備中，可作為配件供應。



勿將用過的電動工具、電池/充電電池與家庭廢棄物混合。

當電動工具和電池達到使用壽命時，必須單獨收集，並送至環保回收機構。

請與當地相關部門或經銷商聯繫，了解回收建議和收集地點。

V

伏特



直流電

技术数据	M18 FRT
电池电压	18 V
拉力	20000 N
刀具的行程长度	30.0 mm
夹爪的最大直径	7.0 mm
铆钉的尺寸 \emptyset	
黑色	4.8mm
红色	6.0mm
绿色	6.4mm
棕色	7.0mm
铆钉的材料	铝 铜 钢 不锈钢
重量符合EPTA—Procedure 01/2014 (Li-Ion 2.0 Ah - 12.0 Ah)	2.5 - 3.5 kg
建议环境操作温度	0 - +50 ° C
推荐的电池类型	M18B...; M18HB...
推荐充电器	M12-18...; M1418C6
本测量值符合EN 62841条文的规定。	
A-值声压值	81 dB (A)
不确定性的测量 K	3dB (A)
A-值声功率值	92 dB (A)
不确定性的测量 K	3dB (A)
佩戴防护耳罩。	
依欧盟EN 62841标准确定的振动总值（三方向矢量和）。	
振动值	$a_h = < 2.5 \text{ m/s}^2$
不确定性的测量 K	1.5 m/s^2

⚠ 警告！

本规程列出的依标准测量方法测量的振动级也可用于电动工具比较并适合于临时振动负荷估计。该等级可用于来初步评估风险。

该振动级代表电动工具的主要应用。电动工具的其他应用，不正确的工具附件或缺维护可造成振动级偏差。此可明显提高工作期间的振动程度。

正确地估计一定工作期间的振动程度也要考虑到工具关闭或接通而不使用的期间。此可明确减少总工作期间的振动程度。

为提高操作人员对振动作用的保护得规定补充安全措施：电动工具及工具附件的维护、温手、工作过程组织等。

▲ 警告！请阅读本产品随附的所有安全警告、说明、插图及规格。不遵照以下说明会导致电击、着火和/或严重伤害。

保存所有警告和说明书以备查阅。

铆钉工具安全警告

在紧固件可能触及暗线或其自身软线之处进行操作时，要通过绝缘握持面来握持工具。紧固件碰到带电导线会使工具外露的金属零件带电从而使操作受到电击。

使用防护装备。使用机器时，务必佩戴护目镜。建议穿戴防护装备，例如防尘罩、防护手套、结实的防滑鞋、安全帽和护耳器。

损坏的产品应立即由授权的中心维修。

对产品进行任何工作前，先移除电池。

为避免受伤和损坏，切勿将产品、可拆卸电池或充电器浸入液体中或使液体渗透。

其他安全和工作说明

▲ 警告！为了减少因短路而导致火灾、人身伤害和产品损坏的风险，请勿将工具、电池组或充电器浸没在液体中或使流体流入其中。腐蚀性或导电性流体（如海水、某些工业化学品、以及漂白剂或含漂白剂的产品等）都会导致短路。

不可拆开电池和充电器。电池和充电器必须储藏在干燥的空间，勿让湿气渗入。必须经常保持干燥。

M18系列的电池组只能和M18系列的充电器配合使用。不可以使用其他系列的电池。

警告！本设备包含一个钮扣型/钮扣式锂电池。一个新的或二手的电池可能导致严重的内部灼伤。如果吞咽或进入身体，可在短短2小时内导致死亡。务必固定电池舱的盒盖。如果没有安全地关闭，请停止设备，取出电池，并将其放在儿童接触不到的地方。如果您认为有人吞下了电池或者进入身体，请立即就医。

特定使用条件

本产品的用途为专业的拉钉设定应用。

切勿将本产品用于正常使用之外的其他用途。

残余风险

即使产品按规定使用，依然无法完全消除某些残余风险因素。以下危害可能在使用过程中出现，操作者应特别注意避免以下几点：

- 振动引起的损伤
 - 用指定的手柄握住产品，并限制工作时间和暴露。
- 因接触噪声导致听力伤害
 - 戴耳罩和限制暴露于噪音中。
- 因工作抛出的碎屑导致的伤害
 - 务必佩戴防护眼镜，重型长裤、手套及结实的鞋类。
- 吸入尘屑而导致的健康危险
 - 在必要情况下可戴面具。

电池

长期储放的电池必须先充电再使用。

超过50°C (122°F) 的高温会降低电池组的效能。避

免暴露于高温或阳光下（可能导致过热）。

充电器和电池组的接点处应保持清洁。

为获得最长寿命，使用后应将电池充满电。

为确保最长使用寿命，充电后应将电池从充电器取出。

电池储存时间长于30日：

- 在环境温度27°C左右干燥处储存电池；
- 在百分之30至50充电状态储存电池；
- 每6个月重新充电。

电池超载保护

在极高的扭矩、结合、停滞和引起高电流消耗短路的情况下，工具将振动约5秒，电池灯会闪烁，然后工具将关闭。如要重置，松开扳机。

如要重置，松开扳机。在这种情况下，电池的内部温度可能会变高。如果发生这种情况，电池灯会闪烁，直至电池冷却下来。灯熄灭后，可以继续工作。

锂电池的运输

锂电池属于危险货品并受制于危险货品运输条例。

此电池的运输必须遵守地方、国家和国际法律规定。

- 用户在公路上运输此电池组不必遵守特殊规定；
- 锂电池的商业性运输受制于危险货品运输条例的规定。运输准备和运输必须由受过合适培训人员进行。全部过程必须由合格专业人员监督。

运输电池时必须注意到下列事项：

- 为避免短路，必须确保电池接点的防护和绝缘；
- 确保包装中的电池包不会滑动；
- 严禁运输损坏或泄漏电池。

进一步建议请联系运输商。

清洁

本产品的通风孔必须时刻保持畅通。

维护

只能使用美沃奇的附件和零件。

如果需要更换的组件在此没有介绍，请与其中一个美沃奇服务代理机构联系（参见我们的保修/服务地址列表）。

若需要，您可以订购本工具的分解图。请向您的顾客服务中心提供以下资料：铭牌上机器的号码和机型。

符号



启动机器前，请仔细阅读本说明书。



注意！警告！危险！



对产品进行任何工作前，先移除电池。



使用本产品时务必佩戴护目镜。



佩戴手套。



附件 - 不在标配设备中，可作为附件供应。



勿将用过的电动工具、电池/充电电池与家庭废弃物混合。
当电动工具和电池达到使用寿命时，必须单独收集，并送至环保回收机构。
请与当地主管部门或经销商联系，了解回收建议和收集地点。

V

伏特



直流电

기술 데이터	M18 FRT
배터리 전압	18 V
인장력	20000 N
공구 스트로크 길이	30.0 mm
최대 요 직경	7.0 mm
리벳 크기	
검정색	4.8mm
붉은색	6.0mm
녹색	6.4mm
갈색	7.0mm
리벳 재료	알루미늄 구리 강철 스테인리스강
EPTA 규정 01/2014에 따른 중량(리튬-이온 2.0 Ah - 12.0 Ah)	2.5 - 3.5 kg
권장 주변 작동 온도	0 - +50 °C
권장 배터리 팩	M18B...; M18HB...
권장 충전기	M12-18...; M1418C6
EN 62841에 따라 결정되는 잡음 방출 값	
가중치 음압 레벨	81 dB (A)
불확정성 K	3dB (A)
가중치 음향 파워 레벨	92 dB (A)
불확정성 K	3dB (A)
귀마개를 착용하십시오!	
EN 62841에 따라 판별한 총 진동 값(3축 백터 총합)	
진동 방출 값	$a_n = < 2.5 \text{ m/s}^2$
불확정성 K	1.5 m/s^2

경고!

이 지침 설명서에 표시되어 있는 진동 총 수치와 소음 방출 수치는 표준화된 테스트에 따라 측정되었으며 공구끼리 서로 비교하는 데 사용할 수 있습니다. 노출 예비 평가에 사용할 수 있습니다.

표시된 진동 및 소음 방출 수치는 공구의 주 용도로 사용 시에 측정된 값을 나타냅니다. 하지만 공구를 다른 용도로 사용하거나, 다른 부속품과 함께 사용하거나, 부실하게 유지보수할 경우에는 진동 및 소음 방출 수준이 달라질 수 있습니다. 이런 조건은 총 작업 시간에 대한 노출 수준을 상당히 증가시킬 수 있습니다.

진동 및 소음 노출 수준을 추정할 때는 공구의 전원을 끄거나 공회전되는 시간을 고려해야 합니다. 이런 조건은 총 작업 시간에 대한 노출 수준을 상당히 감소시킬 수 있습니다.

공구와 부속품의 유지, 손의 보온 상태 유지(진동의 경우), 작업 패턴 구성과 같이, 작업자를 진동 및 소음의 영향으로부터 보호하기 위한 추가 안전 대책을 파악하십시오.

⚠ 경고! 공구와 함께 제공된 제반 안전 경고, 사용 설명서, 그림 및 사양을 숙지하십시오. 아래의 지침을 따르지 않으면 전기 충격, 화재 및 중대한 부상을 초래할 수 있습니다.

항후 참조할 수 있도록 경고 문구와 설명서를 잘 보관해 두십시오.

리벳 공구 안전 주의 사항

패스너가 보이지 않는 배선과 접촉할 수 있는 장소에서 작업을 수행할 경우에만 절연 그림 표면을 통해 전동 공구를 잡으십시오. "전원 공급" 배선과 접촉하면 전동 공구의 노출된 금속 부분도 "전원 공급"되어 작업자에게 전기 쇼크를 야기할 수 있습니다.

보호 장구를 착용하십시오. 방호복 사용이 권고됨. 예: 먼진 마스크, 방호 장갑, 견고하고 미끄럼 방지 신발, 헬멧, 방음장치

손상 부품은 인가된 서비스 센터에서 즉시 수리하십시오.

제품 사용 전, 배터리 팩을 제거하십시오.

부상 및 손상을 방지하려면 제품, 배터리 팩 또는 충전기를 액체에 침수시키거나 액체가 통과하지 않도록 해야 합니다.

추가적인 안전 및 작업 지침

⚠ 경고! 단락 회로로 인한 화재, 작업자 부상 및 제품 손상 위험을 줄이려면 물, 배터리 팩 또는 충전기를 유체에 침수시키거나 유체가 내부로 흘러들어가지 않도록 해야 합니다. 해수, 특정한 산업용 화학 물질 및 표백제 또는 표백제 함유 제품 같은 부식성 또는 전도성 유체 등은 단락 회로를 야기할 수 있습니다.

배터리 팩과 충전기를 개방하지 말고, 건조한 곳에 보관하십시오. 배터리 팩과 충전기는 항상 건조한 상태로 유지하십시오.

System M18 배터리 팩을 충전하려면 System M18 충전기만 사용하십시오. 다른 시스템의 배터리 팩을 사용하지 마십시오.

경고! 본 제품에는 버튼 타입의 코인셀 리튬 배터리가 포함되어 있습니다. 신규 또는 종고 배터리액을 삼키거나 체내로 들어갈 경우 심각한 내상을 야기하고 2시간 이내에 사망에 이를 수 있습니다. 항상 배터리 구획에 덮개를 확실하게 덮으십시오. 확실하게 닫히지 않을 경우 장치 사용을 중지하고 배터리를 분리한 다음, 어린이가 닿지 않는 곳에 보관하십시오. 누군가가 배터리 액을 흡입하였거나 배터리 액이 신체에 유입되었다고 생각되면 즉시 의료 조치를 취하십시오.

지정된 사용 조건

이 블라인드 리벳 전동 공구는 전문 블라인드 리벳 고정 장치용으로 설계되었습니다.

다른 목적으로 제품을 사용하지 마십시오.

잔류 위험

제품을 설명서대로 사용하더라도 위험 요소를 완전히 제거하는 것은 여전히 불가능합니다. 사용 중에 다음과 같은 위험이 발생할 수 있으며, 작업자는 위험 상황을 피하기 위해 특별한 주의를 기울여야 합니다.

- 진동으로 인한 부상
 - 지정된 핸들을 이용해 제품을 붙잡아 사용하고 작업 시간과 진동에 대한 노출을 적절히 제한하십시오.

- 소음에 노출되면 청력 손상을 입을 수 있습니다.
 - 청력 보호구를 착용하고 소음에 대한 노출을 제한하십시오.
- 비산하는 파편으로 인한 부상
 - 항상 눈 보호 장치, 길이가 긴 바지, 장갑 및 안전화를 착용하십시오.
- 독성 먼지 흡입으로 인한 건강 위험
 - 필요할 경우 마스크를 착용하십시오.

배터리

장시간 사용하지 않은 배터리 팩은 사용하기 전에 충전해야 합니다.

50°C를 초과하는 온도는 배터리 팩의 성능을 저하시킵니다. 열이나 햇볕에 오래 노출시키지 마십시오(과열 위험).

충전기 접점 및 배터리 팩을 청결한 상태로 유지해야 합니다.

최적의 수명을 보장하려면 사용한 후에 배터리 팩을 완전히 충전해야 합니다.

배터리 수명을 최대한 연장하려면 완전히 충전된 경우 충전기에서 배터리 팩을 제거하십시오.

30일 이상 배터리 팩을 보관하는 경우:

- 온도가 27°C 이하이며 습기가 없는 장소에 배터리 팩을 보관하십시오.
- 배터리 팩을 30% - 50% 충전된 조건으로 보관하십시오.
- 보관한지 6개월이 경과할 때마다 팩을 정상적으로 충전하십시오.

배터리 팩 보호

매우 높은 토크에서, 고전류 드로우를 야기하는 결속, 실속 및 단락 회로 상황이 발생하고, 공구가 약 5초 동안 진동하며 연료 게이지가 깜박인 다음, 공구가 꺼집니다.

재설정하려면 트리거를 해제하십시오. 극심한 환경 조건에서, 배터리 팩의 내부 온도가 급격히 상승할 수 있습니다. 온도가 급격히 상승하면 배터리 팩이 냉각될 때까지 연료 게이지가 깜박입니다. 조명이 꺼진 후에는 작업을 계속할 수 있습니다.

리튬 배터리의 운송

리튬 이온 배터리는 위험물 법률 요건의 적용을 받습니다. 이 배터리는 현지, 국내 및 국제 규정과 법규에 따라 운송해야 합니다.

- 배터리는 추가 요구 사항 없이 도로를 통해 운송할 수 있습니다.
- 제3자가 리튬 이온 배터리를 상용으로 운송할 때에는 위험물 규정의 적용을 받습니다. 운송 준비 및 운송 작업은 적절히 교육을 이수한 개인만 수행해야 하고 그 과정에 해당 전문가가 동행해야 합니다.

배터리 운송 시 :

- 배터리 접촉면을 보호 및 차단하여 합선 위험을 방지하십시오.
- 배터리 팩이 포장 내에서 움직이지 않도록 고정하십시오.
- 균열 또는 누출이 있는 배터리는 운송하지 마십시오.

추가 지침은 운송 회사에 확인하십시오.

청소

제품의 통기구를 항상 깨끗하게 유지해야 합니다.

유지 관리

반드시 MILWAUKEE 부속품과 MILWAUKEE 예비품을 사용하십시오.

언급하지 않은 구성 부품을 교체해야 하는 경우 MILWAUKEE 서비스 센터 중 한 곳에 문의하십시오(보증/서비스 주소 목록 참조).

필요 시, 제품의 분해 조립도를 주문할 수 있습니다. 라벨에 인쇄되어 있는 제품 유형과 일련 번호를 알려주고 현지 서비스 대리점에서 도면을 주문하십시오.

기호



제품 사용 전, 설명서를 자세히 읽으십시오.



주의! 경고! 위험!



제품 사용 전, 배터리 팩을 제거하십시오.



제품을 사용할 때 항상 보안경을 착용하십시오.



장갑을 착용하십시오!



부속품 - 기본 제품에는 포함되어 있지 않습니다. 부속품으로 별도 구입해야 합니다.



전동 공구, 배터리/충전식 배터리는 가정용 쓰레기와 함께 버리지 마십시오. 수명이 다한 전동 공구와 배터리는 별도로 수거하여 환경적으로 호환되는 재생 시설로 반품해야 합니다. 재활용에 관한 조건과 수거 지점에 대해서는 지방 정부당국이나 소매업자에게 확인하십시오.

V

전압



직류

ข้อมูลทางเทคนิค	M18 FRT
แรงดันไฟแบตเตอรี่	18 V
แรงดึง	20000 N
ความยาวช่วงชักของเครื่องมือ	30.0 mm
เส้นผ่านศูนย์กลางสูงสุดของปาก	7.0 mm
ขนาดรีเวียด	
สี่ด้าน	4.8mm
สี่แดง	6.0mm
สี่เขียว	6.4mm
สีน้ำตาล	7.0mm
วัสดุรีเวียด	อลูมิเนียม
	ทองแดง
	เหล็ก
	เหล็กกล้าไร้สนิม
น้ำหนักตามขั้นตอนของ EPTA 01/2014 (Li-Ion 2.0 - 12.0 Ah)	2.5 - 3.5 kg
อุณหภูมิในการทำงานที่แนะนำ	0 - +50 °C
ชุดแบตเตอรี่ที่แนะนำ	M18B...; M18HB...
ชาร์จเจอร์ที่แนะนำ	M12-18...; M1418C6
ค่าการปล่อยเสียงรบกวนที่กำหนดตามมาตรฐาน EN 62841	
ระดับแรงดันของเสียงที่ถ่วงน้ำหนัก A	81 dB (A)
ค่า K แปรผัน	3dB (A)
ระดับกำลังของเสียงที่ถ่วงน้ำหนัก A	92 dB (A)
ค่า K แปรผัน	3dB (A)
โปรดสวมอุปกรณ์ปกป้องการได้ยิน	
ค่าการสั่นโดยรวม (ค่าสรุปเวกเตอร์ 3 ทิศทาง) ที่กำหนดตาม EN 62841	
ค่าการปล่อยการสั่นสะเทือน	$a_h = < 2.5 \text{ m/s}^2$
ค่า K แปรผัน	1.5 m/s ²

คำเตือน!

ค่าระดับการสั่นสะเทือนรวมที่ระบุและค่าระดับเสียงดังรบกวนที่ระบุในเอกสารคู่มือการใช้งานฉบับนี้ได้รับการวัดผลตามการทดสอบที่เป็นไปตามมาตรฐานและอาจนำไปใช้เพื่อเปรียบเทียบเครื่องมือหนึ่งๆ กับผลิตภัณฑ์อื่น สามารถใช้สำหรับการประเมินความเสี่ยงในเบื้องต้น ค่าการสั่นสะเทือนและการเสียงดังรบกวนที่ระบุเป็นข้อมูลสำหรับการใช้งานหลักของเครื่องมือ อย่างไรก็ตาม หากเครื่องมือถูกใช้งานผิดประเภท กับอุปกรณ์เสริมที่แตกต่างกัน หรือการบำรุงรักษาไม่ดีพอ ระดับการสั่นสะเทือนและเสียงดังรบกวนอาจจะแตกต่างกันออกไป สภาพเหล่านี้อาจทำให้ระดับความเสี่ยงเพิ่มขึ้นอย่างมีนัยสำคัญตลอดช่วงเวลาการทำงานทั้งหมด

ควรพิจารณาประเมินระดับความเสี่ยงของการสั่นและเสียงดังรบกวนทุกครั้งที่เปิดเครื่องมือหรือขณะที่เครื่องกำลังเดินเบา สภาพเหล่านี้อาจทำให้ระดับความเสี่ยงลดลงอย่างมีนัยสำคัญตลอดทั้งระยะเวลาการทำงาน

ระบุมาตรการความปลอดภัยเพิ่มเติมเพื่อปกป้องผู้ปฏิบัติงานจากผลกระทบของการสั่นสะเทือนและเสียงดังรบกวน เช่น การบำรุงรักษาเครื่องมือและอุปกรณ์เสริม รักษามือให้อบอุ่น (ในกรณีการสั่นสะเทือน) และจัดระเบียบการทำงาน

⚠ คำเตือน! อ่านวิธีใช้ ภาพประกอบ ข้อมูลจำเพาะ และคำเตือนด้านความปลอดภัยทั้งหมดที่ใหม่กับผลิตภัณฑ์ การไม่ปฏิบัติตามคำแนะนำที่แสดงอยู่ด้านล่าง อาจทำให้เกิดไฟฟ้าช็อตเพลิงไหม้ และ/หรือการบาดเจ็บรุนแรงได้

โปรดเก็บเอกสารคำเตือนและคำแนะนำทั้งหมดเพื่อใช้อ้างอิงในอนาคต

คำเตือนเพื่อความปลอดภัยในการใช้เครื่องยี่ห้อ

จับเครื่องมือไฟฟ้าที่บริเวณพื้นผิวสำหรับการจับที่เป็นฉนวนเท่านั้นเมื่อปฏิบัติงาน ในสภาพที่ด้วยมือจะสัมผัสกับการเดินสายไฟที่ซ่อนภายใน การสัมผัสกับสายไฟ "ที่มีกระแสไฟฟ้าวิ่งผ่าน" จะส่งผลให้ชิ้นส่วนโลหะเปลี่ยนมือเครื่องมือไฟฟ้า "มีกระแสไฟฟ้าวิ่งผ่าน" ด้วยเช่นกัน และผู้ปฏิบัติงานอาจถูกไฟฟ้าช็อตได้

โปรดใช้อุปกรณ์ป้องกัน แนะนำให้สวมเสื้อผ้าที่ใช้เพื่อการป้องกัน เช่น หมวกกันน็อก ถุงมือป้องกัน รองเท้ากันลื่นที่มีความปลอดภัย หมวกกันน็อกและเครื่องป้องกันหู

หากพบชิ้นส่วนเสียหาย ให้ส่งซ่อมที่ศูนย์ซ่อมที่ได้รับอนุญาตทันที ถอดชุดแบตเตอรี่ออกก่อนเริ่มกระทำการใด ๆ กับผลิตภัณฑ์

ห้ามจุ่มผลิตภัณฑ์ช้อ แบตเตอรี่ หรือที่ชาร์จลงในของเหลวหรือปล่อยให้ของเหลวซึมผ่านเพื่อหลีกเลี่ยงการบาดเจ็บหรือความเสียหาย

คำแนะนำเพิ่มเติมเรื่องความปลอดภัยและการใช้งาน

⚠ คำเตือน! วิธีลดความเสี่ยงในการเกิดไฟไหม้ การบาดเจ็บส่วนบุคคล และความเสี่ยงหายต่อผลิตภัณฑ์ จากการลัดวงจร อย่าจุ่มเครื่องมือ ก้อนแบตเตอรี่ หรือเครื่องชาร์จไฟลงในของเหลวหรือปล่อยให้ของเหลวซึมเข้าสู่ภายใน ของเหลวที่มีฤทธิ์กัดกร่อนหรือนำไฟฟ้าอาจก่อให้เกิดการลัดวงจรได้ เช่น น้ำทะเล สารเคมีทางอุตสาหกรรมบางชนิด และผลิตภัณฑ์ฟอกสีหรือมีส่วนผสมการฟอกสี เป็นต้น

ห้ามเปิดทำลายแบตเตอรี่และเครื่องชาร์จและเก็บไว้ในห้องที่แห้งเท่านั้น เก็บก่อนแบตเตอรี่และอุปกรณ์ชาร์จในที่แห้งตลอดเวลา

ชาร์จชุดแบตเตอรี่ System M18 ด้วยตัวชาร์จสำหรับ System M18 เท่านั้น อย่าใช้แบตเตอรี่จากระบบอื่น ๆ

คำเตือน! ผลิตภัณฑ์นี้บรรจุแบตเตอรี่ลิเทียมแบบกระดุม หากกลืนหรือมีแบตเตอรี่ใหม่หรือแบตเตอรี่ที่ใช้แล้วเข้าสู่ร่างกาย อาจทำให้เกิดอาการเสาร้อนภายในและนำไปเสียชีวิตได้ภายในเวลา 2 ชั่วโมงเป็นอย่างน้อย ปิดฝาครอบช่องใส่แบตเตอรี่ให้สนิทตลอดเวลา หากฝาครอบแบตเตอรี่ปิดไม่สนิท ให้หยุดใช้อุปกรณ์ ถอดแบตเตอรี่ออก และเก็บให้ห่างจากเด็ก หากคุณเชื่อว่ามีส่วนกลืนกินแบตเตอรี่หรือมีแบตเตอรี่เข้าสู่ร่างกาย ให้รีบพบแพทย์โดยด่วน

สภาพการใช้งานที่กำหนด

เครื่องยี่ห้อไฟฟ้านี้ออกแบบมาเพื่อการติดตั้งรีริตอย่างมืออาชีพ ห้ามใช้ผลิตภัณฑ์เพื่อวัตถุประสงค์อื่นนอกเหนือจากที่ระบุ

ความเสี่ยงที่หลีกเลี่ยง

ถึงแม้เครื่องมือจะได้รับการใช้ตามที่กำหนด แต่ก็ไม่สามารถกำจัดปัจจัยความเสี่ยงที่หลงเหลืออยู่ได้ อัตราตายต่อไปนี้อาจเกิดขึ้นในการใช้งานและผู้ดำเนินการควรให้ความสนใจเป็นพิเศษเพื่อหลีกเลี่ยงกรณีต่อไปนี้

- การบาดเจ็บที่เกิดจากแรงสั่นสะเทือน
 - จับบริเวณที่จับเฉพาะของผลิตภัณฑ์และอย่าใช้งานติดต่อกันเป็นเวลานาน
- เสียงดังเกินไปอาจทำให้สูญเสียความสามารถในการได้ยิน
 - สวมอุปกรณ์ป้องกันการได้ยินและจำกัดระยะเวลาการได้ยิน
- การบาดเจ็บเนื่องจากเศษวัสดุที่กระเด็น

- สวมใส่อุปกรณ์ป้องกันดวงตา กางเกงขายาวที่มีความหนา ถุงมือและรองเท้าที่แข็งแรงทนทานตลอดเวลา
- อันตรายต่อสุขภาพที่อาจสูญหายอาจผ่านพิษเข้าไป
 - สวมหน้ากากถ้าจำเป็น

แบตเตอรี่

ควรชาร์จแบตเตอรี่ที่ไม่ได้ใช้งานเป็นระยะเวลาหนึ่งก่อนที่จะใช้งาน ประสิทธิภาพของชุดแบตเตอรี่จะลดลงหากอุณหภูมิสูงกว่า 50°C หลีกเลี่ยงไม่ให้ถูกแสงแดดหรือความร้อนเป็นเวลานาน (เสียงต่อความร้อนเกิน)

ต้องหมั่นดูแลความสะอาดหน้าสัมผัสตัวชาร์จกับชุดแบตเตอรี่ เพื่อยืดอายุการใช้งาน ควรชาร์จแบตเตอรี่ให้เต็มหลังการใช้งาน เพื่อรักษาอายุแบตเตอรี่ให้มากที่สุด ให้ถอดชุดแบตเตอรี่ออกจากตัวชาร์จเมื่อชาร์จไฟเต็ม

สำหรับชุดแบตเตอรี่ที่ต้องการเก็บไว้นานกว่า 30 วัน:

- เก็บชุดแบตเตอรี่ไว้ที่อุณหภูมิต่ำกว่า 27°C และหลีกเลี่ยงความชื้น
- เก็บชุดแบตเตอรี่ไว้ที่ประจุ 30% - 50%
- ให้ชาร์จแบตเตอรี่ตามปกติทุกหกเดือนที่เก็บ

ระบบป้องกันของชุดแบตเตอรี่

ในสถานการณ์ที่เกิดแรงดันสูง ตัดขาด สุด และเกิดการลัดวงจร เนื่องจากมีกระแสย้อนกลับสูง เครื่องมือจะสั่นเป็นเวลา 5 วินาที และเกจน้ำมันจะกะพริบ แล้วเครื่องมือจะดับลง

การรีเซ็ต ปล่อยให้ ภายใต้อุณหภูมิที่รุนแรง อุณหภูมิภายในของแบตเตอรี่อาจสูงเกินไป หากเกิดเหตุการณ์นี้ขึ้น เกจน้ำมันจะกะพริบจนกว่าแผงแบตเตอรี่จะเย็นลง หลังจากที่ได้ดับลง เครื่องจะสามารถใช้งานได้

การเคลื่อนย้ายแบตเตอรี่ลิเทียม

แบตเตอรี่ลิเทียมไอออนอยู่ภายใต้ข้อกำหนดตามกฎหมายของสินค้าอันตราย การขนส่งแบตเตอรี่เหล่านี้ต้องกระทำตามกฎระเบียบและข้อบังคับของท้องถิ่น ของประเทศ และระหว่างประเทศ

- สามารถขนส่งแบตเตอรี่ทางถนนได้โดยไม่ต้องมีข้อกำหนดเพิ่มเติม
- การขนส่งแบตเตอรี่ลิเทียมไอออนเชิงพาณิชย์โดยนิติบุคคลอื่นต้องดำเนินการภายใต้กฎระเบียบว่าด้วยสินค้าที่มีอันตราย การเตรียมการขนส่งและการขนส่งต้องดำเนินการโดยบุคลากรที่ผ่านการฝึกอบรมมาแล้วเท่านั้น และในระหว่างดำเนินการต้องมีผู้เชี่ยวชาญที่เกี่ยวข้องคอยกำกับดูแล

เมื่อขนย้ายแบตเตอรี่:

- ตรวจสอบให้แน่ใจว่าข้อต่อแบตเตอรี่ได้รับการปกป้องและหุ้มฉนวนเพื่อป้องกันไฟฟ้าลัดวงจร
- โปรดตรวจสอบให้แน่ใจว่าแบตเตอรี่ได้รับการบรรจุห่ออย่างมั่นคงเพื่อป้องกันการขยับเขยื้อน
- ห้ามเคลื่อนย้ายแบตเตอรี่ที่แตกหรือรั่ว

โปรดสอบถามบริษัทขนส่งหากท่านต้องการคำแนะนำเพิ่มเติม

การทำความสะอาด

ต้องให้ช่องระบายอากาศเปิดโล่งอยู่ตลอดเวลา

การบำรุงรักษา

ใช้อุปกรณ์เสริมและชิ้นส่วนสำรองของ MILWAUKEE เท่านั้น หากจำเป็นต้องเปลี่ยนส่วนประกอบที่ไม่ได้อธิบายไว้ โปรดติดต่อศูนย์บริการของ MILWAUKEE (ดูที่รายการการรับประกัน/ที่อยู่ของศูนย์บริการของเรา)

ท่านสามารถส่งภาพกระขายชิ้นส่วนประกอบขอผลิตภัณฑ์ได้

หากต้องการ โปรดระบุประเภทผลิตภัณฑ์ที่พิมพ์รวมถึงหมายเลข
อนุกรมบนฉลาก และสั่งซื้อตรงอสังที่ตัวแทนบริการภายในท้องถิ่น
ของคุณ

เครื่องหมาย



โปรดอ่านคำแนะนำอย่างระมัดระวังก่อนเริ่มใช้
เครื่องมือ



ระวัง! คำเตือน! อันตราย!



ถอดชุดแบตเตอรี่ออกก่อนเริ่มทำการใด ๆ
กับผลิตภัณฑ์



สวมแว่นตานิรภัยทุกครั้งที่ใช้ผลิตภัณฑ์นี้



สวมถุงมือ



อุปกรณ์เสริม - ไม่รวมอยู่ในผลิตภัณฑ์มาตรฐาน
มีให้เป็นอุปกรณ์เสริม



อย่าทิ้งเครื่องมือไฟฟ้า แบตเตอรี่ แบตเตอรี่ชนิด
ชาร์จซ้ำได้ร่วมกับขยะในครัวเรือน ต้องทิ้งเครื่อง
มือไฟฟ้าและแบตเตอรี่ที่หมดอายุการใช้งานแยก
ต่างหากและนำไปยังสถานที่รีไซเคิลที่เป็นมิตร
กับสิ่งแวดล้อม ตรวจสอบกับผู้มีอำนาจในท้องถิ่น
ของคุณหรือร้านค้าปลีกสำหรับคำแนะนำในการ
รีไซเคิลและจุดเก็บรวบรวม

V

แรงดันไฟฟ้า



กระแสดรง

DATA TEKNIS	M18 FRT
Tegangan baterai	18 V
Gaya tarik	20000 N
Panjang kayuhan alat	30,0 mm
Diameter maksimal rahang	7,0 mm
Ukuran paku keling (rivet)	
Hitam	4,8mm
Merah	6,0mm
Hijau	6,4mm
Cokelat	7,0mm
Bahan paku keling (rivet)	Aluminium
	Tembaga
	Baja
	Baja tahan berkarat
Bobot sesuai dengan Prosedur EPTA 01/2014 (Li-ion 2,0 Ah - 12,0 Ah)	2,5 - 3,5 kg
Suhu pengoperasian sekitar yang direkomendasikan	0 - +50 °C
Paket baterai yang direkomendasikan	M18B...; M18HB...
Pengisi daya yang direkomendasikan	M12-18...; M1418C6
Nilai emisi derau ditentukan menurut EN 62841	
Tingkat tekanan suara tertimbang A	81 dB (A)
K Ketidakpastian	3dB (A)
Tingkat daya suara tertimbang A	92 dB (A)
K Ketidakpastian	3dB (A)
Pakai pelindung telinga.	
Nilai total vibrasi (jumlah vektor triaksial) ditentukan sesuai dengan EN 62841	
Nilai misi getaran	$a_n = < 2,5 \text{ m/s}^2$
K Ketidakpastian	1,5 m/s ²

PERINGATAN!

Tingkat getaran total yang dinyatakan dan tingkat emisi derau yang dinyatakan dalam lembaran informasi ini telah diukur sesuai dengan uji standar dan dapat digunakan untuk membandingkan satu alat dengan alat lainnya. Dapat digunakan untuk penilaian awal keterpaparan.

Tingkat getaran dan emisi derau yang dinyatakan menggambarkan aplikasi utama alat ini. Namun jika alat ini digunakan untuk aplikasi yang berbeda, dengan aksesoris yang berbeda atau tidak dirawat dengan baik, getaran dan emisi kebisingan yang timbul mungkin berbeda. Kondisi ini dapat meningkatkan tingkat paparan secara signifikan sepanjang periode kerja keseluruhan.

Perkiraan tingkat paparan terhadap getaran dan derau juga harus memperhitungkan saat-saat ketika alat dimatikan atau ketika produk sedang dinyalakan tetapi tidak digunakan. Kondisi ini dapat menurunkan tingkat paparan secara signifikan selama periode kerja total.

Identifikasi langkah-langkah keselamatan tambahan untuk melindungi operator dari efek getaran dan derau, seperti merawat peralatan dan aksesoris, menjaga tangan tetap hangat (terkait getaran), dan mengatur pola kerja.

⚠ PERINGATAN! Baca semua peringatan keselamatan, petunjuk, ilustrasi, dan spesifikasi yang disertakan bersama produk. Tidak dipatuhinya semua petunjuk di bawah ini, dapat berakibat sengatan listrik, kebakaran, dan/atau cedera parah.

Simpan semua peringatan dan petunjuk sebagai referensi sewaktu-waktu.

PERINGATAN KESELAMATAN ALAT KELING (RIVET TOOL)

Pegang alat listrik dengan permukaan genggam berinsulasi, saat melakukan pengoperasian di mana pengencang mungkin bersentuhan dengan perkabelan tersembunyi. Kontak dengan kabel yang "beraliran listrik" juga akan membuat komponen logam perkakas listrik yang terbuka menjadi "beraliran listrik" dan membuat operator tersetrum.

Gunakan peralatan pelindung. Dianjurkan memakai pakaian pelindung, seperti masker debu, sarung tangan pelindung, sepatu alas karet yang kokoh, helm, dan pelindung telinga.

Komponen yang rusak harus segera diperbaiki di pusat servis resmi.

Lepaskan paket baterai sebelum memulai pekerjaan apa pun pada produk.

Untuk menghindari cedera dan kerusakan, jangan merendam produk, unit baterai atau pengisi daya dalam cairan atau membiarkan cairan masuk ke dalamnya.

PETUNJUK KESELAMATAN DAN KERJA TAMBAHAN

⚠ PERINGATAN! Untuk mengurangi risiko kebakaran, cedera pribadi, dan kerusakan produk akibat hubungan arus pendek, jangan pernah merendam alat, baterai atau charger Anda dalam cairan atau membiarkan cairan mengalir di dalamnya. Cairan korosif atau konduktif, seperti air laut, bahan kimia industri tertentu, dan produk pemutih atau yang mengandung pemutih, dan sebagainya, dapat menyebabkan hubungan arus pendek.

Jangan sekali-kali membuka unit baterai dan pengisi daya serta hanya simpan di tempat kering. Jaga kemasan baterai dan pengisi daya tetap kering di sepanjang waktu.

Hanya gunakan pengisi daya System M18 untuk mengisi daya paket baterai System M18. Jangan menggunakan unit baterai dari sistem lain.

PERINGATAN! Produk ini mengandung baterai sel litium berbentuk kancing/koin. Baterai baru atau bekas dapat menyebabkan luka bakar internal yang parah dan menyebabkan kematian dalam waktu 2 jam jika tertelan atau masuk ke dalam tubuh. Selalu kunci penutup kompartemen baterai. Jika penutup tidak menutup dengan aman, hentikan penggunaan perangkat, lepaskan baterai, dan jauhkan dari anak-anak. Jika Anda yakin seseorang telah menelan baterai atau baterai telah masuk ke dalam tubuh dengan cara lain, segera cari bantuan medis.

KONDISI PENGGUNAAN KHUSUS

Alat keling listrik tanpa lubang ini dirancang untuk aplikasi pemasangan keling buntu secara profesional. Jangan menggunakan produk untuk tujuan lain.

RISIKO RESIDU

Bahkan ketika produk digunakan seperti yang ditentukan, masih tidak mungkin untuk sepenuhnya menghilangkan faktor risiko residual tertentu. Bahaya berikut mungkin timbul dalam penggunaan dan operator harus memberikan perhatian khusus untuk menghindari hal-hal berikut:

- cedera yang disebabkan oleh vibrasi
 - Pegang produk dengan menggunakan tuas yang disediakan dan batasi waktu kerja dan paparan.
- Berada di lingkungan yang bising dapat menyebabkan gangguan pendengaran.
 - Gunakan pelindung telinga dan batasi paparan.
- Cedera akibat terbang serpihan
 - Gunakan pelindung mata, celana panjang tebal, sarung tangan dan alas kaki yang kuat setiap saat.
- bahaya kesehatan yang disebabkan oleh menghirup debu beracun
 - Gunakan masker jika perlu.

BATERAI

Paket baterai yang belum digunakan selama beberapa waktu harus diisi kembali dayanya sebelum digunakan.

Suhu yang melebihi 50°C akan mengurangi kinerja paket baterai. Hindari paparan berkepanjangan terhadap panas atau sinar matahari (risiko panas berlebihan).

Kontak pada pengisi daya dan paket baterai harus dijaga kebersihannya.

Untuk masa pemakaian optimal, paket baterai harus diisi dayanya hingga penuh setelah digunakan.

Untuk memaksimalkan masa pemakaian baterai, lepaskan paket baterai dari pengisi daya setelah terisi sepenuhnya.

Untuk penyimpanan paket baterai lebih dari 30 hari:

- Simpan paket baterai jika suhu berada di bawah 27°C dan jauhkan dari kelembapan.
- Simpan paket baterai dalam kondisi terisi dayanya 30% - 50%.
- Jika penyimpanan paket baterai mencapai enam bulan, isi daya baterai seperti biasa.

PERLINDUNGAN KEMASAN BATERAI

Dalam torsi yang sangat tinggi, mengikat, mogok dan situasi arus pendek yang menyebabkan tarikan arus tinggi, alat akan bergetar selama sekitar 5 detik, pengukur bahan bakar akan berkedip, dan kemudian alat akan padam.

Untuk menyetel ulang, lepaskan pemacu. Dalam kondisi ekstrem, suhu dalam baterai dapat

meningkat. Jika hal ini terjadi, pengukur bahan bakar akan berkedip hingga paket baterai menjadi lebih dingin. Setelah lampu tersebut padam, Anda dapat melanjutkan pekerjaan.

MENGANGKUT BATERAI LITUM

Baterai litium-ion tunduk pada persyaratan Legislasasi Barang Berbahaya. Pengangkutan baterai ini harus dilakukan sesuai regulasi dan peraturan daerah, nasional, dan internasional.

- Baterai dapat diangkat melalui jalan darat tanpa persyaratan khusus.
- Pengangkutan komersial baterai Litium-ion oleh pihak ketiga tunduk pada peraturan Barang Berbahaya. Persiapan pengangkutan dan pengangkutan harus dilakukan oleh orang yang terlatih dan prosesnya harus didampingi oleh pakar yang terkait.

Ketika mengangkut baterai:

- Pastikan bahwa terminal kontak baterai terlindungi dan terisolasi untuk mencegah korsleting.
- Pastikan wadah baterai sudah dikencangkan agar tidak terpengaruh oleh pergerakan di dalam pengemasannya.
- Jangan mengangkut baterai yang retak atau bocor.

Tanyakan kepada perusahaan ekspedisi untuk mendapatkan saran lebih lanjut.

PEMBERSIHAN

Slot ventilasi produk tidak boleh tertutup sepanjang waktu.

PEMELIHARAAN

Gunakan hanya aksesoris MILWAUKEE dan suku cadang MILWAUKEE.

Jika komponen yang belum dijelaskan harus diganti, hubungi salah satu dari pusat layanan MILWAUKEE kami (lihat daftar alamat layanan/garansi kami).

Jika diperlukan, gambar pecahan komponen dapat dipesan. Sebutkan tipe produk dan nomor seri yang tertera pada label dan pesanlah gambarnya pada agen layanan setempat.

SIMBOL



Baca petunjuk dengan cermat sebelum memulai menggunakan produk.



PERHATIAN! PERINGATAN!
BAHAYA!



Lepaskan paket baterai sebelum memulai pekerjaan apa pun pada produk.



Selalu pakai kaca mata goggle saat menggunakan produk ini.



Pakai sarung tangan!



Aksesoris - Tidak disertakan dalam produk standar, tersedia sebagai aksesoris.



Jangan membuang alat-alat listrik, baterai/baterai isi ulang bersama-sama dengan sampah rumah tangga. Peralatan listrik dan baterai yang telah mencapai akhir masa pakainya harus dikumpulkan secara terpisah dan dikembalikan ke fasilitas daur ulang yang kompatibel terhadap lingkungan. Tanyakan kepada pihak berwenang atau peritel setempat mengenai daur ulang dan titik pengumpulan.

V

Voltase



Arus Searah

THÔNG SỐ KỸ THUẬT**M18 FRT**

Điện áp pin	18 V
Lực kéo	20000 N
Độ dài hành trình của công cụ	30,0 mm
Đường kính đường tròn tối đa	7,0 mm
Kích cỡ đinh tán	
Đen	4,8mm
Đỏ	6,0mm
Xanh lục	6,4mm
Nâu	7,0mm
Vật liệu đinh tán	Nhôm
	Đồng
	Thép
	Thép không gỉ
Trọng lượng theo Quy Trình EPTA 01/2014 (Li-ion 2,0 Ah - 12,0 Ah)	2,5 - 3,5 kg
Nhiệt độ môi trường khuyến nghị khi vận hành	0 - +50 °C
Loại pin được khuyến nghị	M18B...; M18HB...
Bộ sạc được khuyến nghị	M12-18...; M1418C6
Giá trị phát sinh tiếng ồn được xác định theo tiêu chuẩn EN 62841.	
Cấp độ áp suất âm thanh trọng số A	81 dB (A)
Độ bất định K	3dB (A)
Cấp độ công suất âm thanh trọng số A	92 dB (A)
Độ bất định K	3dB (A)
Đeo thiết bị bảo vệ tai.	
Tổng giá trị rung (tổng vectơ 3 trục) được xác định theo EN 62841	
Giá trị phát thải rung chấn	$a_n = < 2,5 \text{ m/s}^2$
Độ bất định K	1,5 m/s^2

 CẢNH BÁO!

Tổng giá trị mức độ rung chấn và giá trị phát thải tiếng ồn được công bố được đưa ra trong hướng dẫn sử dụng này đã được đo theo thử nghiệm chuẩn hóa đã cho có thể được sử dụng để so sánh với công cụ khác. Có thể sử dụng chúng để đánh giá sơ bộ về mức độ tiếp xúc.

Các giá trị phát thải tiếng ồn và rung chấn được công bố thể hiện cho ứng dụng chính của công cụ. Tuy nhiên, nếu sản phẩm được sử dụng cho các ứng dụng khác nhau, với các phụ kiện khác nhau hoặc được bảo dưỡng kém, thì mức độ phát thải rung chấn và tiếng ồn có thể khác nhau. Những điều kiện này có thể làm tăng đáng kể mức độ tiếp xúc trong tổng thời gian làm việc.

Việc ước tính mức độ tiếp xúc với tiếng ồn và rung chấn cần tính đến số lần công cụ được tắt hoặc khi nó đang chạy không tải. Những điều kiện này có thể làm giảm đáng kể mức độ tiếp xúc trong tổng thời gian làm việc.

Xác định các biện pháp an toàn bổ sung để bảo vệ người vận hành khỏi các tác động của rung chấn và tiếng ồn, như bảo trì công cụ và các phụ kiện, giữ cho tay ấm (trong trường hợp rung chấn), sắp xếp các quy trình làm việc.

⚠ CẢNH BÁO! Hãy đọc tất cả các cảnh báo an toàn, hướng dẫn, hình minh họa và thông số kỹ thuật đi kèm dụng cụ có động cơ này. Không tuân thủ những cảnh báo và chỉ dẫn có thể dẫn đến giật điện, hỏa hoạn và/hoặc chấn thương nghiêm trọng.

Giữ lại tất cả những cảnh báo và chỉ dẫn để tham khảo sau này.

CẢNH BÁO AN TOÀN CHO CÔNG CỤ TÁN ĐÍNH

Giữ máy bằng bề mặt cầm cách điện, chỉ khi thực hiện một thao tác trong đó mô cắt đứt có thể tiếp xúc với dây điện ẩn. Tiếp xúc với dây điện "sống" sẽ dẫn điện cho các phần kim loại bị hở của máy và khiến người vận hành bị điện giật.

Sử dụng thiết bị bảo hộ. Nên sử dụng quần áo bảo hộ, chẳng hạn như mặt nạ chống bụi, găng tay bảo vệ, giày dép chống trơn trượt, mũ bảo hiểm và thiết bị bảo vệ tai.

Sửa chữa mọi hư hại ngay lập tức bởi một trung tâm bảo dưỡng được ủy quyền.

Tháo bình pin trước khi bắt đầu thao tác với sản phẩm.

Để tránh nguy cơ bị chấn thương và hư hại, không bao giờ nhúng sản phẩm, bộ pin hoặc bộ sạc trong chất lỏng hoặc để chất lỏng xâm nhập vào chúng.

HƯỚNG DẪN AN TOÀN VÀ HOẠT ĐỘNG BỔ SUNG

⚠ CẢNH BÁO! Để giảm nguy cơ hỏa hoạn, chấn thương cá nhân và hư hại sản phẩm do ngắn mạch, không bao giờ nhúng sản phẩm, pin hay bộ sạc trong chất lỏng hoặc cho phép chất lỏng xâm nhập vào chúng. Các chất lỏng ăn mòn hoặc dẫn điện, ví dụ như nước biển, một số hóa chất công nghiệp, và chất tẩy hoặc sản phẩm chứa chất tẩy, v.v., đều có thể gây ngắn mạch.

Không bao giờ phá vỡ các bình pin và bộ sạc, và chỉ bảo quản chúng trong các phòng khô. Luôn đảm bảo các bình pin và bộ sạc được khô.

Chỉ sử dụng các bộ sạc M18 System để sạc pin M18 System. Không sử dụng bình pin từ các hệ thống khác.

CẢNH BÁO! Sản phẩm có chứa pin lithium loại nút/đồng xu. Pin mới hoặc đã qua sử dụng có thể gây bỏng bên trong nghiêm trọng và có thể dẫn đến tử vong sau ít nhất 2 giờ nếu nuốt phải hoặc nếu pin xâm nhập vào cơ thể. Luôn đậy chặt nắp lên ngăn chứa pin. Nếu ngăn chứa không được đậy chặt, hãy dừng sản phẩm, tháo pin và để xa tầm tay trẻ em. Nếu bạn cho rằng ai đó đã nuốt phải pin hoặc pin đã xâm nhập vào cơ thể người đó, hãy tìm đến sự chăm sóc y tế ngay lập tức.

ĐIỀU KIỆN SỬ DỤNG CỤ THỂ

Công cụ tán đinh đầu chìm điện này được thiết kế cho các ứng dụng tán đinh đầu chìm chuyên nghiệp.

Không sử dụng sản phẩm cho bất kỳ mục đích nào khác.

RỦI RO CÓ HỮU

Ngay cả khi sử dụng sản phẩm theo chỉ định, thì vẫn không thể loại bỏ hoàn toàn các yếu tố rủi ro còn lại.

Các mối nguy hiểm sau đây có thể phát sinh khi sử dụng sản phẩm và người vận hành cần đặc biệt chú ý để tránh những điều sau đây:

- chấn thương do rung động
 - Giữ sản phẩm bằng tay cầm được chỉ định và hạn chế thời gian làm việc và tiếp xúc.
- tiếp xúc với tiếng ồn có thể gây tổn thương thính giác
 - Đeo đồ bảo vệ tai và hạn chế tiếp xúc.
- bị thương do mảnh vỡ bay ra
 - Luôn đeo đồ bảo vệ mắt, mặc quần dài dày, đeo găng tay và đi giày dép vừa vặn.
- mối nguy hiểm cho sức khỏe do hít phải bụi độc hại
 - Đeo khẩu trang nếu cần.

PIN

Các bình ắc quy chưa được sử dụng trong một thời gian dài nên được sạc lại trước khi sử dụng.

Nhiệt độ vượt quá 50°C làm giảm hiệu năng của bình pin. Tránh tiếp xúc trong thời gian dài với nhiệt độ hoặc ánh nắng mặt trời (nguy cơ quá nhiệt).

Các đầu tiếp xúc của bộ sạc và bình pin phải được giữ sạch.

Để có tuổi thọ tối ưu, các pin phải được sạc đầy sau mỗi lần sử dụng.

Để đảm bảo tuổi thọ pin lâu nhất có thể, hãy rút pin ra khỏi bộ sạc sau khi nó được sạc đầy.

Để bảo quản bình pin lâu hơn 30 ngày:

- Bảo quản bình pin ở nơi khô, có nhiệt độ dưới 27°C.
- Bảo quản pin trong điều kiện sạc 30% - 50%
- Sau mỗi 6 tháng bảo quản, sạc pin như bình thường.

BẢO VỆ PIN

Trong các tình huống mômen xoắn cao, kẹt, kẹt và ngắn mạch có thể tăng cường độ dòng điện, sản phẩm sẽ rung khoảng 5 giây, đèn báo mức pin sẽ nhấp sáng, và sau đó sản phẩm bị tắt.

Để đặt lại, hãy nhả cơ ra. Trong các tình huống khác nghiệt, nhiệt độ bên trong của pin có thể trở nên quá cao. Nếu điều này xảy ra, đèn báo mức pin sẽ nhấp sáng cho đến khi pin nguội bớt. Sau khi đèn tắt, bạn có thể tiếp tục làm việc.

VẬN CHUYỂN PIN LITHIUM

Các bình pin lithium-ion cần tuân thủ Luật về Hàng hóa Nguy hiểm. Việc vận chuyển các pin này phải được thực hiện theo các điều kiện và quy định của địa phương, quốc gia và quốc tế.

- Pin có thể được vận chuyển bằng đường bộ mà không có yêu cầu nào khác.
- Việc vận chuyển thương mại pin lithium-ion bởi các bên thứ ba cần tuân thủ quy định về Hàng hóa Nguy hiểm. Việc chuẩn bị vận chuyển và vận chuyển cần được thực hiện bởi những người được đào tạo phù hợp và quy trình này phải được

giám sát bởi các chuyên gia trong ngành.

Khi vận chuyển pin:

- Đảm bảo các đầu tiếp xúc của pin được bảo vệ và cách điện để ngăn ngắn mạch.
- Đảm bảo pin được cố định để không di chuyển trong bao bì.
- Không vận chuyển các pin bị nứt hoặc rò rỉ.

Kiểm tra với công ty chuyển tiếp để được tư vấn thêm.

LÀM SẠCH

Các khe thông gió của sản phẩm lúc nào cũng phải sạch sẽ.

BẢO TRÌ

Chỉ sử dụng các phụ kiện và phụ tùng thay thế của MILWAUKEE.

Không được thay thế các thành phần theo những cách không được mô tả ở đây, vui lòng liên hệ một trong những đại lý dịch vụ MILWAUKEE của chúng tôi (xem danh sách địa chỉ bảo hành/dịch vụ của chúng tôi).

Nếu cần, có thể yêu cầu xem hình vẽ mô tả chi tiết các bộ phận. Vui lòng nêu rõ số sê-ri cũng như loại sản phẩm được in trên nhãn và yêu cầu bản vẽ tại các trung tâm dịch vụ địa phương của bạn.

BIỂU TƯỢNG



Vui lòng đọc cẩn thận hướng dẫn trước khi sử dụng máy.



CHÚ Ý! CẢNH BÁO! NGUY HIỂM!



Tháo bìnhpin trước khi bắt đầu thao tác với sản phẩm.



Luôn đeo kính bảo vệ khi sử dụng sản phẩm.



Đeo găng tay!



Phụ kiện - Không có ở sản phẩm tiêu chuẩn; được cung cấp dưới dạng phụ kiện.



Không vứt bỏ các dụng cụ điện, pin/pin có thể sạc lại cùng với rác thải sinh hoạt. Các dụng cụ điện và pin đã hết hạn sử dụng phải được thu gom riêng và đưa về một cơ sở tái chế phù hợp với môi trường. Xác nhận với chính quyền địa phương hoặc nhà bán lẻ để được tham vấn về việc tái chế và điểm thu gom.

V

Điện áp



Dòng điện một chiều

技術データ	M18 FRT
バッテリー電圧	18 V
引張力	20000 N
工具のストローク長さ	30.0 mm
最大あご径	7.0 mm
リベット寸法	
黒	4.8mm
赤	6.0mm
緑	6.4mm
茶	7.0mm
リベット材料	アルミニウム 銅 スチール ステンレス鋼
本体重量 (リチウムイオン2.0 Ah~12.0 Ahバッテリー装着時) (EPTA 01/2014準拠)	2.5 - 3.5 kg
推奨周囲動作温度	0 - +50 °C
推奨バッテリータイプ	M18B...; M18HB...
推奨充電器	M12-18...; M1418C6
騒音放射値 (EN 62841に従い測定)	
A特性・音圧レベル	81 dB (A)
不確かさ K	3dB (A)
A特性音響パワーレベル	92 dB (A)
不確かさ K	3dB (A)
耳栓を使用してください。	
総振動値 (3軸のベクトル和) (EN 62841に従い測定)	
振動放出値	$a_n = < 2.5 \text{ m/s}^2$
不確かさ K	1.5 m/s ²

警告！

本情報シートに記載されている振動/騒音放射レベルは、EN 62841の所与の標準検査に従って測定されたものであり、ある工具と別の工具を比較するために使用することができません。暴露の予備評価にも使用できません。

公表された振動・騒音値は、工具の主な用途を表しています。ただし、工具が異なる用途に使用され、付属品が異なっている、メンテナンスが不十分であるなどの場合は、振動/騒音放射が異なる場合があります。これらの条件により、総作業期間にわたる暴露レベルが大幅に増加する可能性があります。

暴露する振動・騒音値の概算を出す場合、工具のスイッチがオフになっている時間、または工具がアイドルング中である時間も考慮する必要があります。これらの条件により、総作業期間にわたる暴露レベルが大幅に減少する可能性があります。

振動/騒音の影響からオペレーターを保護するために、次のような追加安全対策を確認してください：工具と付属品のメンテナンスを行う、手を温かく保つ、作業パターンを整理する。

A 警告！本電動工具に同梱されているすべての安全警告、指示、図、仕様をお読みください。下記のすべての指示に従わない場合、感電や火災が発生したり、重傷を負う可能性があります。

今後の参考のために、すべての警告と指示を保存します。

リベット工具の安全警告

隠し配線にファスナーが接触する可能性のある操作を行うときは、絶縁グリップ面で電動工具を支えてください。「通電」中の電線に接触すると、電動工具の露出金属部を「通電」させることがあり、その場合、作業者を感電させることがあります。

保護具を使用してください。防塵マスク、保護手袋、滑らない頑丈な履物、ヘルメット、防音具などの防護服を使用してください。

損傷は直ちに認定サービスセンターで修理してください。

製品のメンテナンス、アークセラーを交換する前に、バッテリーパックを取り外してください。

けがや破損を避けるため、製品、電池パック、充電器を液体に浸けたり液体を浸入させたりしないでください。

追加の安全上の注意事項および作業指示

A 警告！漏電による火災、人的損傷、製品破損のリスクを軽減するために、製品、バッテリーパック、充電器を液体に浸したり、液体を流入させたりすることは絶対にしないでください。海水、特定の工業用化学物質、漂白剤または漂白剤を含む製品などの腐食または伝導性誘導体は、漏電の原因となることがあります。

バッテリーと充電器は絶対に分解しないでください。バッテリーと充電器は湿度の低い屋内で保管してください。

M18システム・バッテリーの充電には、M18システムの充電器しか使用できません。別のシステムのバッテリーと混ぜて使用しないでください。

警告！製品にはボタン型/コイン型リチウム電池が含まれます。新しい、または使用済みのバッテリーは、飲み込んだ場合、または体内に入った場合、重度の火傷を引き起こす可能性があり、わずか2時間で死に至る可能性があります。必ずバッテリー収納部にカバーを固定してください。安全に閉まらない場合は製品の使用を中止し、バッテリーを取り外して幼児の手の届かないところに保管してください。バッテリーを誤飲した人がいる、または体内に入ったと思われる場合、ただちに医師の診察を受けてください。

特定の使用条件

このブラインドリベット用電動工具は、ブラインドリベット取り付けの業務向けに設計されています。

本製品を他の用途では使用しないでください。

残存リスク

製品が規定どおりに使用された場合でも、特定の残存する危険因子を完全に排除することは不可能です。使用中に以下の危険が発生することがあり、作業者は以下を回避するために特に注意する必要があります。

- 振動による怪我
 - 所定のハンドルを持って本製品を保持し、作業時間や暴露を制限します。
- 騒音にさらされると、難聴を引き起こすおそれがあります。
 - 耳保護具を着用して、曝露を制限します。
- 飛散した破片によるけが
 - 目の保護具、高強度の長ズボン、グローブ、安全靴をつねに着用してください。
- 有毒な粉塵の吸い込みによる健康上の危険性
 - 必要な場合はマスクを着用してください。

バッテリー

しばらく使用していなかったバッテリーパックは使用前に再度充電を行ってください。

50°Cを超える温度下ではバッテリーパックの性能が低下します。直射日光や高熱に長時間さらさないようにしてください（オーバーヒートの危険性があります）。

充電器とバッテリーの接点を清潔に保ってください。

最適な寿命を保つため、使用後はバッテリーパックを完全に充電してから保管してください。

バッテリー寿命を最大に保つためにバッテリーをフル充電してから充電器から取り外してください。

バッテリーパックを30日以上保管する場合は：

- 温度27度未満で湿気がない場所に保管する。
- 30～50%の充電状態で保管する。
- 6ヶ月ごとにバッテリーを通常通りに充電する。

バッテリーパックの保護

極めて高いトルク、ビンディング、停動、および高電流を引き起こす短絡状態では、製品は約5秒間振動して燃料計が点滅してからオフになります。

リセットするには、トリガーを解除してください。過酷な環境下では、バッテリーパック内の温度が過剰に上昇する場合があります。この現象が起きると、バッテリーパックが冷たくなるまで燃料計が点滅します。ライトが消えた後も、作動し続ける場合があります。

リチウムバッテリーの輸送

リチウムイオンバッテリーは、危険物規制の要件の対象となります。このバッテリーの輸送は、地域、国、および国際的な規定および規制に従って行わなければならない。

- バッテリーの地上輸送には、それ以上の要件はありません。
- 第三者によるリチウムイオンバッテリーの商業輸送には、危険物規制が適用されます。輸送の準備と輸送は、適切な訓練を受けた人員のみが実施し、その作業には対応する専門家の同行が必要で

バッテリーを輸送する場合は：

- バッテリーの接触端子は、漏電を防ぐために保護と絶縁の処理がされていることを確認してください。
- バッテリーパックがパッケージ内で動かないよう

に固定されていることを確認してください。

- ひびが入ったり液漏れが発生しているバッテリーは輸送しないでください。

詳細については、運送会社に確認してください。

お手入れ

充電の際、充電器の排気口を塞がないでください。

メンテナンス

ミルウォーキー (MILWAUKEE) の純正アクセサリとサービスパーツをご使用ください。

記載されていない部品を交換する必要がある場合は、MILWAUKEEサービスセンターにお問い合わせください（保証リストまたはサービス所在地リストを参照してください）。

必要に応じて、製品の分解立体図をご注文いただけます。製品タイプとシリアル番号をラベルにご記入のうえ、お近くのサービスセンターで分解立体図をご注文ください。

記号



製品の使用を開始する前に、指示を注意深くお読みください。



注意！警告！危険！



製品のメンテナンス、アクセサリを交換する前に、バッテリーパックを取り外してください。



製品を使用する際は、必ずゴーグルを着用してください。



手袋を着用してください！



付属品：標準製品には含まれていません。



電動工具、バッテリー/充電式バッテリーを家庭廃棄物と一緒に廃棄しないでください。寿命に達した電動工具とバッテリーは、個別に回収し、リサイクルを行ってください。リサイクルに關しましては、お住いの自治体または販売店までご相談ください。

V

電圧



直流







